



Produktname

## 2-armiger Universal Abzieher mit selbstzentrierenden Abzughaken







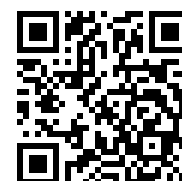

Zum Abziehen von Lagern, Zahnrädern, Scheiben etc.

Art. Nr. 44-1

Baureihe 44

EAN 4021176016028



	Technisches Attribut	Metrisch	Imperial
	Spannweite außen	12 - 100 mm	1/2 - 3 7/8 inch
	Spanntiefe	100 mm	3 7/8 inch
	Außensechskant	13 mm	
max.	Maximal zulässige Belastung	3 t	3 US t
	Max. Drehmoment	50 Nm	6.5 ft lb
	Gewicht	0.525 kg	
	Raum unterhalb	7 mm	1/4 inch
	Raum nebendran	20 mm	3/4 inch
	Anzahl Haken	2	2



## Technologien



### SWITCH

Optimale Anpassung der Spindel an die Welle durch zweiseitige Spindelspitze.



### AUTOGRIP

Die Abzughaken werden automatisch gespannt und zentriert.



## Ersatzteil

<b>Art. Nr.</b>	<b>Produktname</b>
44-1-T	Traverse
44-1-100-P	2 Abzughaken (Paar)
44-1-206	Traverseninnenbuchse mit Spindel
612130	Mechanische Druckspindel.

## Zubehör

<b>Art. Nr.</b>	<b>Produktname</b>
K-600-014	Wechseldruckstück-Set für KUKKO Druckspindeln

## Ist Bestandteil von

<b>Art. Nr.</b>	<b>Produktname</b>
EVLW-2-INDUSTRIE	Verkaufswand Industrie
WT-1-INDUSTRIE	Abzieher-Sortiment - Industrie
EVLW-INDUSTRIE BASIC	Verkaufswand Industrie

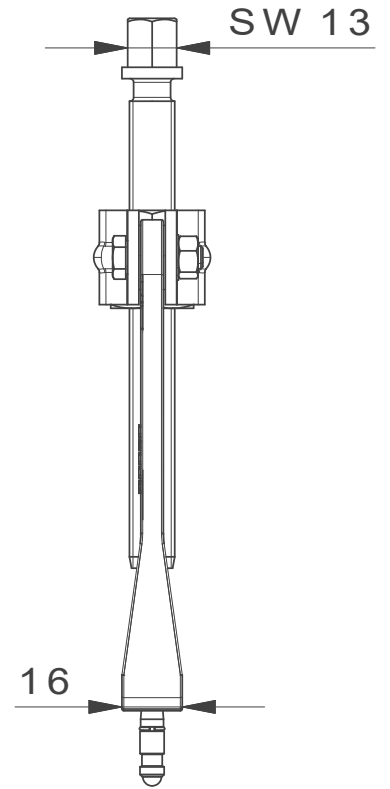
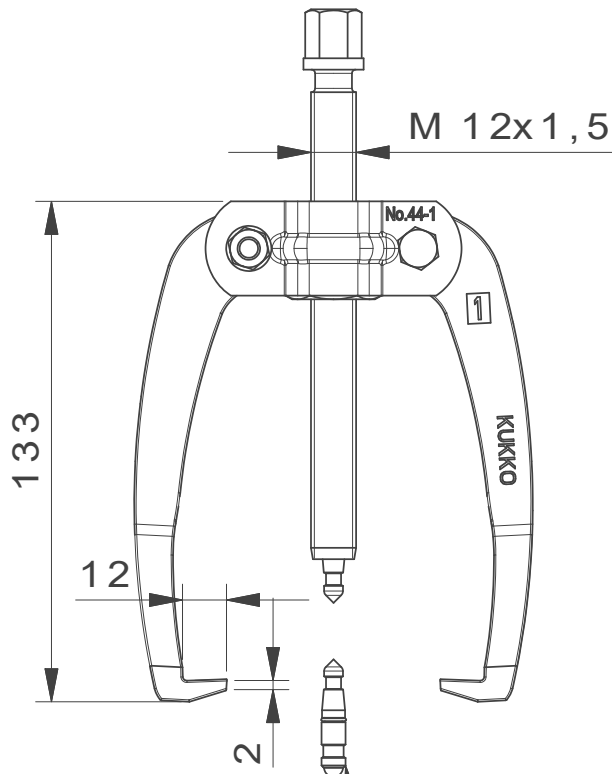

Mit Wechseldruckstück

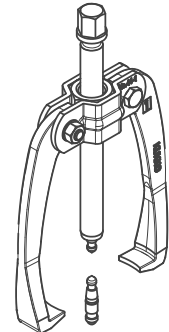
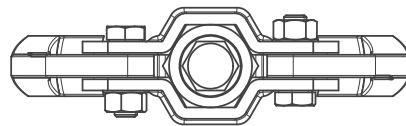

 <p><b>Kleinbongartz &amp; Kaiser oHG</b> Werkzeugfabrik Hilden - Germany</p>	Dokumentname: 44-1_2-armiger Universal Abzieher		Toleranz: DIN ISO 2768-m
	Dokumentbeschreibung: Baugruppe		Material: Hoch legierter Werkzeugstahl / High alloy tool steel
	Erstellt von: Breidenbach	Erstellungsdatum: 02/03/2016	Maßstab: 1:2
Teilbeschreibung:  2-armiger Universal Abzieher/ Universal 2-jaw puller with self-centering jaws		Wärmebehandlung / Härte: vergüteter Stahl/ tempered steel	
		Oberflächenbehandlung:	
Artikelnummer / ZNR.: 44-1	Dokumentversion: -	Schutzvermerk ISO 16016 beachten	