

Case fasteners

3885.20.000E

Case fastener for lead seal, galvanized steel, with adjustable buckle, without hook



Technical data

Material	Steel
Finish	Galvanized

Packaging

Weight / unit	0.19 kg
Quantity / pack	20

Dimensions (mm)

h	Ø	s	a1	a3	b1
22	4.5	2	112	90	28
b2	b3				
23,5	44				

The number of holes may vary from the image

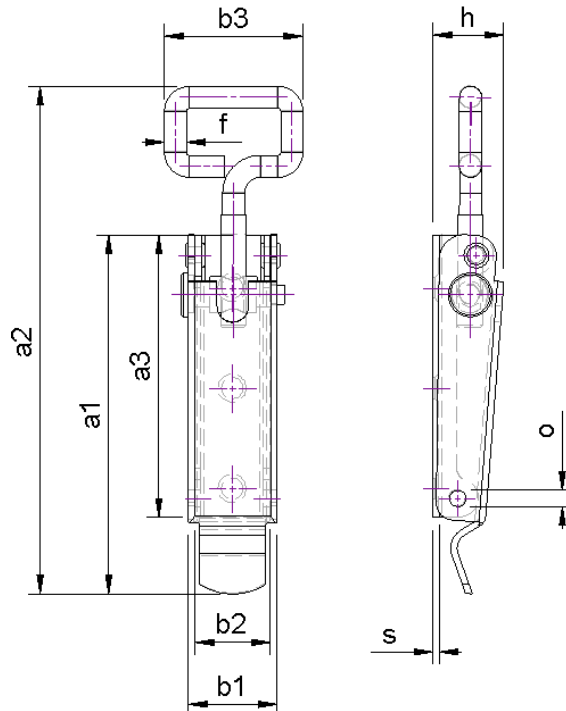

Assembly

Screws

Number	2	Size	4.5
--------	---	------	-----