

Certified True Translation

Allgemeine bauaufsichtliche Zulassung

**Zulassungsnummer:
Z-14.4-776**

Antragsteller:

SFS intec GmbH
In den Schwarzwiesen 2
61440 Oberursel, Germany

Zulassungsnummer = Approval Number Geltungsdauer = Period of validity
Antragsteller = applicant Zulassungsgegenstand = subject of approval

Zulassungsgegenstand:

Fasteners for connection of steel structural members in steel and high bay warehouse structures

The above-mentioned subject of approval is herewith granted a national technical approval (allgemeine bauaufsichtliche Zulassung).

This national technical approval comprises seven pages and 44 annexes.

This national technical approval is to replace the national technical approval No. Z-14.4-776 dated 30 September 2016. The subject of approval was first given national technical approval on 30 September 2016.

Zulassungsstelle für Bauprodukte und Bauarten

Bautechnisches Prüfamt

Eine vom Bund und den Ländern
gemeinsam getragene Anstalt des öffentlichen Rechts

Mitglied der EOTA, der UEAtc und der WFTAO

Datum: Geschäftszeichen:

11 January 2017 I 36-1.14.4-100/16

Geltungsdauer

vom: **11 January 2017**

bis: **30 September 2021**

DIBt

DIBt | Kolonnenstraße 30 B | D-10829 Berlin | Tel.: +49 30 78730-0 | Fax: +49 30 78730-320 | E-Mail: dibt@dibt.de | www.dibt.de



I. GENERAL PROVISIONS

1. With this national technical approval, the fitness for use and the applicability of the subject of approval in accordance with the Regional Building Regulations (Landesbauordnungen) are verified.
2. If requirements are made in the national technical approval concerning the special expertise and experience of persons entrusted with the manufacture of construction products and types of construction in accordance with the relevant regional regulations following section 17, sub-section 5, of the Model Building Code (Musterbauordnung), it should be noted that this expertise and experience can also be proven by equivalent verifications from other Member States of the European Union. When appropriate, this also applies to verifications presented within the framework of the Agreement on the European Economic Area (EEA) or other bilateral agreements.
3. The national technical approval does not replace the permits, approvals and certificates prescribed by law for carrying out building projects.
4. This national technical approval is granted without prejudice to the rights of third parties, in particular private property rights.
5. Notwithstanding further regulations in the 'Specific Provisions', manufacturers and distributors of the subject of approval shall make copies of the national technical approval available to the user and point out that the national technical approval must be available at the place of use. Upon request, copies of the national technical approval shall be placed at the disposal of the authorities involved.
6. The national technical approval may only be reproduced in full. Partial publication requires the consent of the German Construction Engineering Institute (Deutsches Institut für Bautechnik). Texts and drawings in advertising brochures may not contradict the national technical approval. Translations of the national technical approval must contain the note "This translation was not officially approved by the Deutsches Institut für Bautechnik (German Construction Engineering Institute)".
7. This national technical approval is valid until revoked. The provisions of the national technical approval may subsequently be supplemented and amended, in particular if this is required by new technical findings.

II. SPECIFIC PROVISIONS

1. Subject of approval and field of application

Subjects of approval are the thread rolling screws, TDBL-T-8.6xL, TDBLF-T-8.6xL, TDBLF-T-F-8.6xL, TDBL-T-10.6xL, TDBLF-T-10.6xL, TDBL-T-13.4xL und TDBLF-T-13.4xL, which were produced with carburised steel and provided with a Cr(VI) free zinc flake coating. Details and dimensions are given in Annex 1.

Examples of connections using the screws TDBL-T-8.6xL, TDBLF-T-8.6xL, TDBLF-T-F-8.6xL, TDBL-T-10.6xL, TDBLF-T-10.6xL, TDBL-T-13.4xL and TDBLF-T-13.4xL may be found in Annexes 2 to 6. The fastener types along with profile tables are described in Annex 7.

The field of application and the pre-drilling diameters of the screws may be found in Annexes 9 to 11.

The thread forming screws TDBL may be used in place of the standard screws in accordance with DIN EN 15048¹ for bearing type shear connections pursuant to DIN EN 1993-1-8² in connection with the National Annex.

The screws and the corresponding connections may be subject to shear force, tension, or a combination of both (transverse tension at any angle). The characteristic values of design resistance for the respective load are given in the annexes. The screws are intended for connecting and/or joining steel structural members to each other. The structural member which is fastened (on screw head side) is component I and the supporting element is component II. The intended application includes the use of the screws TDBL-T-8.6xL, TDBLF-T-8.6xL, TDBLF-T-F-8.6xL, TDBL-T-10.6xL, TDBLF-T-10.6xL, TDBL-T-13.4xL and TDBLF-T-13.4xL and their connections indoors and outdoors up to corrosivity category C3, in accordance with DIN EN ISO 12944-2³, as long as the influence of sulphides and chlorides is excluded.

The screws are intended for use in connections subject to static and quasistatic load (i.e. constant strain, wind strain).

2. Provisions for the construction product

2.1 Properties and composition

2.1.1 Dimensions

The principal dimensions (nominal dimensions) of the screws TDBL-T-8.6xL, TDBLF-T-8.6xL, TDBLF-T-F-8.6xL, TDBL-T-10.6xL, TDBLF-T-10.6xL, TDBL-T-13.4xL and TDBLF-T-13.4xL must correspond to the specifications in Annex 1. Further specifications regarding dimensions and tolerances are filed with the Deutsches Institut für Bautechnik (German Construction Engineering Institute).

2.1.2 Material

Regarding the material of the screws and the components to be connected, the specifications in the annexes as well as the documents filed with the Deutsches Institut für Bautechnik (German Construction Engineering Institute) shall apply.

¹ DIN EN 15048-1:2016-09 Non-preloaded structural bolting assemblies - Part 1: General requirements

² DIN EN 1993-1.8:2010-12 Design of Steel Structures - Part 1-8: Design of joints

³ DIN EN ISO 12944-2:1998-07 Paints and varnishes - Corrosion protection of steel structures by protective paint systems - Part 2: Classification of environments



2.1.3 Production

In accordance with the specifications in the national technical approval, the screws TDBL-T-8.6xL, TDBLF-T-8.6xL, TDBLF-T-F-8.6xL, TDBL-T-10.6xL, TDBLF-T-10.6xL, TDBL-T-13.4xL and TDBLF-T-13.4xL shall be produced according to the production process which is filed with the Deutsches Institut für Bautechnik (German Construction Engineering Institute).

2.1.4 Corrosion protection

The screws may be used up to the corrosivity category C3, in accordance with DIN EN ISO 12944-2³, as long as the influence of sulphides and chlorides is excluded. The corrosion protection of the components to be connected must at least correspond to the corrosion protection required for the respective use.

2.2 Marking

The packaging of the screws or the enclosed leaflet shall be marked by the manufacturer with the conformity mark Ü (Ü-Zeichen) in accordance with the decrees on conformity marking of the States of the Federal Republic of Germany. Marking is only allowed if the conditions given in clause 2.3 are satisfied. All packaging shall have an additional label with information about the factory (factory code), the description, the geometry and the material of the screws. Screws shall have an additional head mark (manufacturer's mark).

2.3 Attestation of conformity

2.3.1 General

The attestation of conformity with the provisions of this national technical approval for the screws shall be issued for every production facility in the form of a certificate of conformity based on factory production control and regular external surveillance, including initial type-testing of the screws in accordance with the following provisions. For issuance of the certificate of conformity and for external surveillance, including the required product testing, the manufacturer of the screws shall engage an approved certification body and an approved inspection body. The manufacturer shall declare that a certificate of conformity has been granted and make said declaration evident by marking the construction products with the mark of conformity (Ü-Zeichen), stating the intended use. The certification body shall send a copy of the certificate of conformity issued by the same to Deutsches Institut für Bautechnik. Regarding the extent, nature and frequency of the factory production control and external surveillance, the Approval Guidelines of the Deutsches Institut für Bautechnik for "attestation of conformity for fasteners in lightweight metal construction" (see issue 6/1999 of "DIBt Mitteilungen") shall apply.

2.3.2 Factory production control

A factory production control system shall be set up and implemented in each production facility. Factory production control is understood to be the continuous surveillance of production by the manufacturer to ensure that the manufactured screws are in compliance with the provisions of this national technical approval. The results of the factory production control shall be recorded and evaluated. The records shall include at least the following information:

- description of the screws or basic material and components,
- type of control or testing,



- date of manufacture and date of testing of the screws or basic material or components,
- results of control and testing and comparison with the requirements filed with the Deutsches Institut für Bautechnik,
- signature of the person responsible for the factory production control.

The records shall be kept for at least five years and be presented to the inspection body involved in the external surveillance. On request, they shall be presented to the Deutsches Institut für Bautechnik and to the German Construction Supervisory Authorities.

If the test results are unsatisfactory, the manufacturer shall immediately take the measures required to eliminate the defect. Screws that do not meet requirements shall be managed in such a way as to preclude mixing with or being mistaken for construction products that comply with requirements. Once the defect has been eliminated, the test involved must be repeated immediately, where technically possible and if necessary to demonstrate elimination of the defect.

2.3.3 External surveillance

The factory production control system at each production facility shall be inspected regularly, i.e. at least twice a year, by means of external surveillance. External surveillance shall include initial type-testing and random sample testing of the screws. Sampling and testing shall be the responsibility of the approved inspection body. The results of certification and external surveillance shall be kept for at least five years. On request, the results shall be presented by the certification or inspection body to the Deutsches Institut für Bautechnik and the German Construction Supervisory Authorities.

3. Provisions for dimensioning and design

3.1 General

Unless otherwise specified, the screws TDBL-T-8.6xL, TDBLF-T-8.6xL, TDBLF-T-F-8.6xL, TDBL-T-10.6xL, TDBLF-T-10.6xL, TDBL-T-13.4xL and TDBLF-T-13.4xL k may be completely or partly exposed to the influence of atmospheric factors up to corrosivity category C3 pursuant to EN ISO 12944-2³ provided that the influence of sulphides and chlorides is excluded. The screws may be used in connections subject to static and/or quasistatic load. The dimensions, material properties and material thickness tN specified in the national technical approval are to be observed. The verification concept for the design of the connections in which the screws are used specified in DIN EN 1990⁴ in connection with the National Annex DIN EN 1990/NA⁵ shall apply. The characteristic values of the design resistance specified in the Annexes shall be used for the design of connections. In the following and in the Annexes, the components to be connected shall be referred to as component I and the component which another component is to be fastened to and/or the substructure shall be referred to as component II.

⁴ DIN EN 1990:2010-12 Eurocode: Basis of structural design

⁵ DIN EN 1990/NA:2010-12 National Annex – Eurocode: Basis of structural design



The characteristic values for the design resistance of the connections are given in the Annexes. Whereas:

$N_{R,k}$ characteristic value for tensile force

$V_{R,k}$ characteristic value for shear force resistance

For intermediate values regarding the thickness of component I or II, the characteristic value may be calculated by linear interpolation. Other component combinations are not permitted. The characteristic values for design resistance which are given in the Annexes take into account the design bearing resistance of the components I and II, the pull-out resistance of the screws in component II, the pull-through resistance of the screws through component I as well as the design resistance of the screws themselves. In addition, the specifications in DIN EN 1993-1-8¹ and DIN EN 1090-2⁶ shall apply, provided that no other specifications are given in this approval. A minimum edge distance of 25 mm is to be observed.

3.2 Connections with thread forming screws TDBL 13.4 x L subject exclusively to shear force, e.g. high bay warehouse structures (Annex 9, Table 1)

The connections in accordance with Annex 9 Table 1 relate to connections with thread forming screws TDBL 13.4 x L which are exclusively subject to shear force. Components I and II lay flush against each other; bending of the screw due to component displacement may be disregarded and solely shear load may be assumed.

For the determination of the design values the following shall apply:

$$V_{Rd} = \frac{V_{Rk}}{\gamma_M}$$

with partial safety coefficient $\gamma_M = 1.33$

The verification applies as well to a single-shear connection with only one row of screws. Washers which are prescribed for such connections pursuant to DIN EN 1993-1-8¹ are not required.

3.3 Connections with thread forming screws subject exclusively to shear force or a combination of tension and shear force

This section shall apply to connections according to Annex 9 Table 2, Annex 10 or Annex 11. In the annexes, fasteners of type a, b, c, d (see Annex 7), which are permissible due to temperature change without any additional verification of the design resistance, are indicated next to the characteristic values of resistance. For other types of fasteners, design constraints must be taken into account, unless there are no constraints or only minor constraints (e.g. sufficient flexibility of the substructure). For the determination of design values the following shall apply:

$$N_{Rd} = \frac{N_{Rk}}{\gamma_M}$$

$$V_{Rd} = \frac{V_{Rk}}{\gamma_M}$$

with partial safety coefficient $\gamma_M = 1.33$

⁶ DIN EN ISO 1090-2:2011-10 Execution of steel structures and aluminium structures - Part 2: Technical requirements for steel structures



For combined stress due to tension and shear force, the following verification procedure for interaction shall apply:

$$\frac{N_{sd}}{N_{Rd}} + \frac{V_{sd}}{V_{Rd}} \leq 1,0$$

3.4 Specific applications

If the thickness of component I is less than 1.25 mm, the design tension resistance is to be reduced according to the arrangement of the screws: - according to the design examples in Annex 8 - (reduce) to 0.7 if the supporting construction is an asymmetrical profile with $t_{II} < 5$ mm. If multiple reductions are to be applied simultaneously, the reduction factors do not have to be combined. The worst-case reduction factor is to be chosen.

4. Provisions for execution

The installation must be executed exclusively according to the specifications of the manufacturer. The manufacturer must provide installation instructions to the company executing the installation. During execution, it must be ensured that no contact corrosion occurs. The screws should not be used in temperatures below -35 degrees Celsius. The screws DBL-T-8.6xL, TDBLF-T-8.6xL, TDBLF-T-F-8.6xL, TDBL-T-10.6xL, TDBLF-T-10.6xL, TDBL-T-13.4xL and TDBLF-T-13.4xL must be installed at a right angle to the surface of the component in order to ensure a faultless structural joint. The component combination and pre-drilling diameter according to the annexes must be observed. The compliance of the installed screws TDBL-T-8.6xL, TDBLF-T-8.6xL, TDBLF-T-F-8.6xL, TDBL-T-10.6xL, TDBLF-T-10.6xL, TDBL-T-13.4xL and TDBLF-T-13.4xL with the national technical approval shall be confirmed by the company executing the installation. The confirmation shall be kept on file.

Uwe Bender
Department Manager

Certified



Ansicht =
View

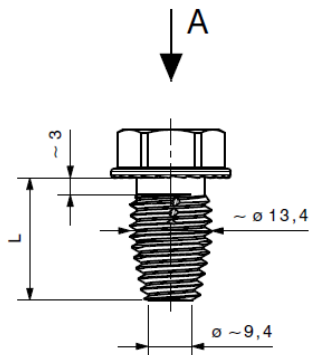

Ansicht A

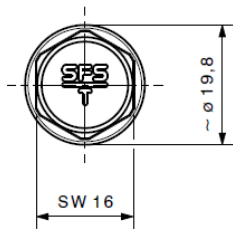

TDBL-T-13.4 x L

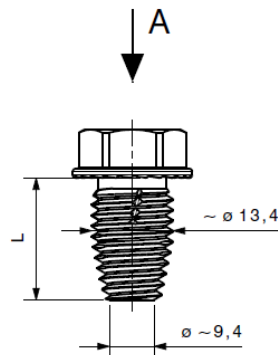

Ansicht A

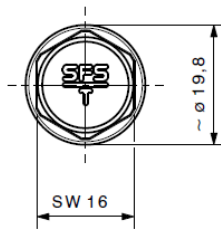

TDBLF-T-13.4 x L

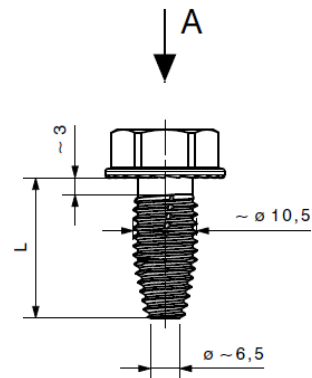

Ansicht A

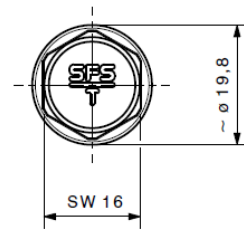

TDBL-T-10.6 x L

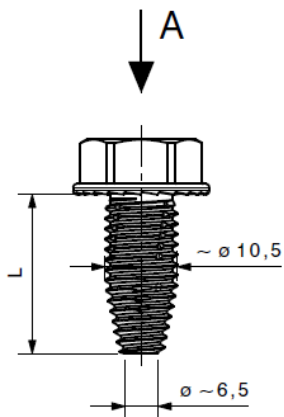

Ansicht A

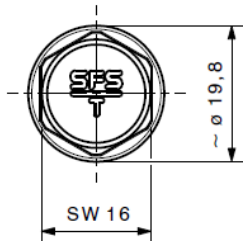

SW = AF

TDBLF-T-10.6 x L

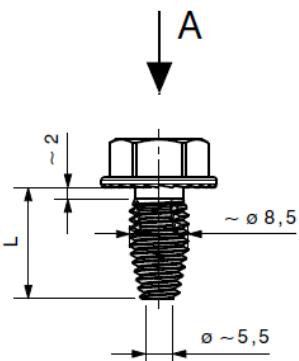

Ansicht A

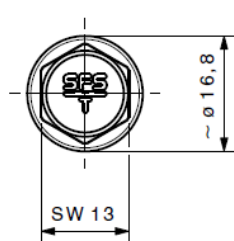

TDBL-T-8.6 x L

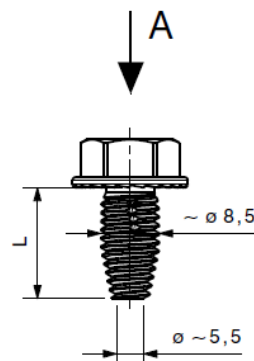

Ansicht A

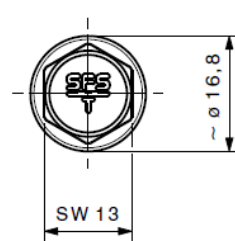

TDBLF-T-8.6 x L

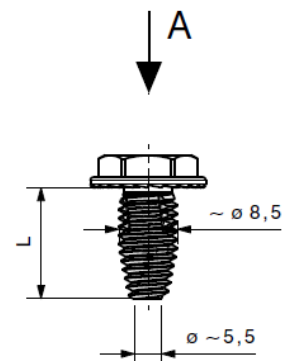

Ansicht A

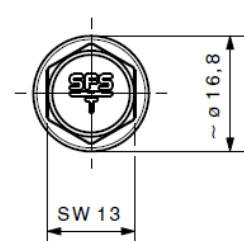

TDBLF-T-F-8.6 x L

Fasteners for connection of steel structural members in steel and high bay warehouse structures

Screw variations

Annex 1

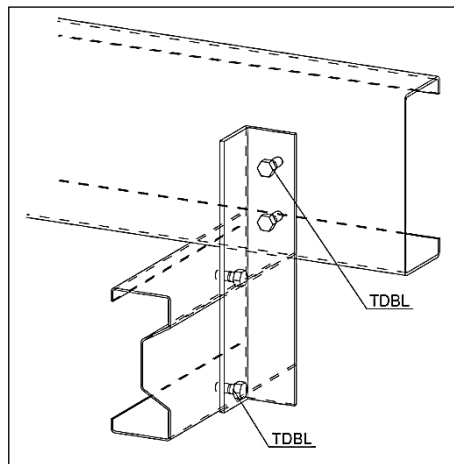
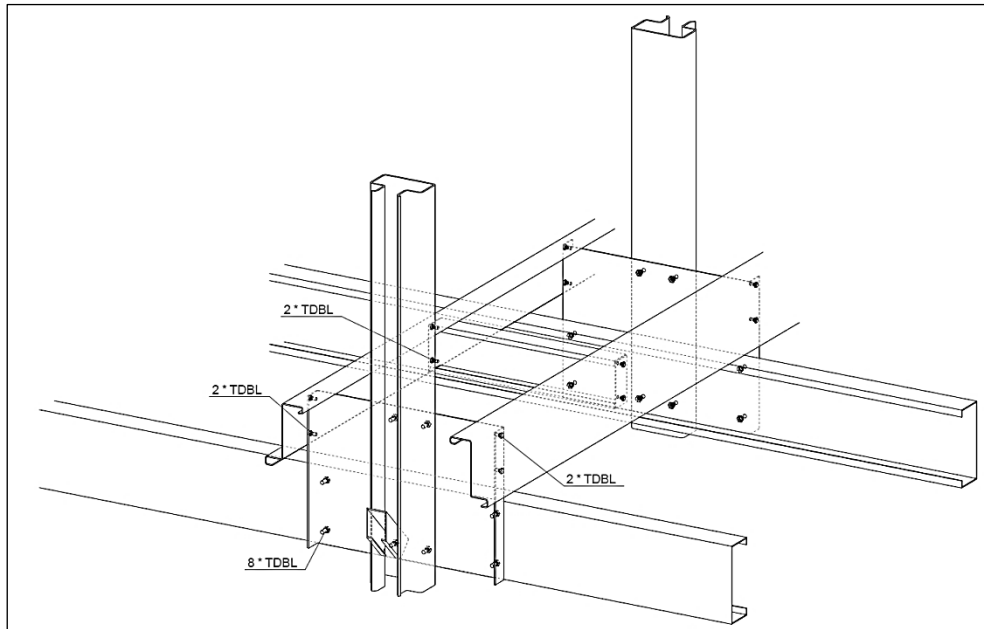
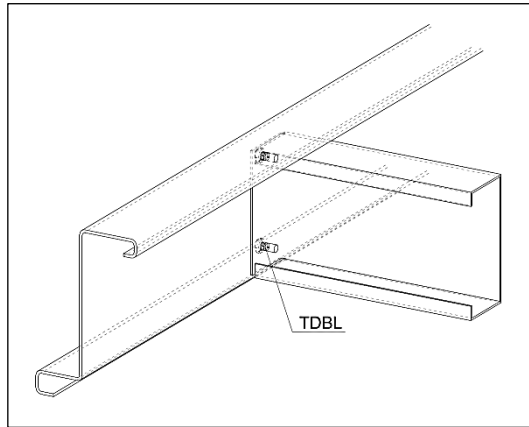

Fasteners for connection of steel structural members in steel and high bay warehouse structures

Application examples

Annex 2

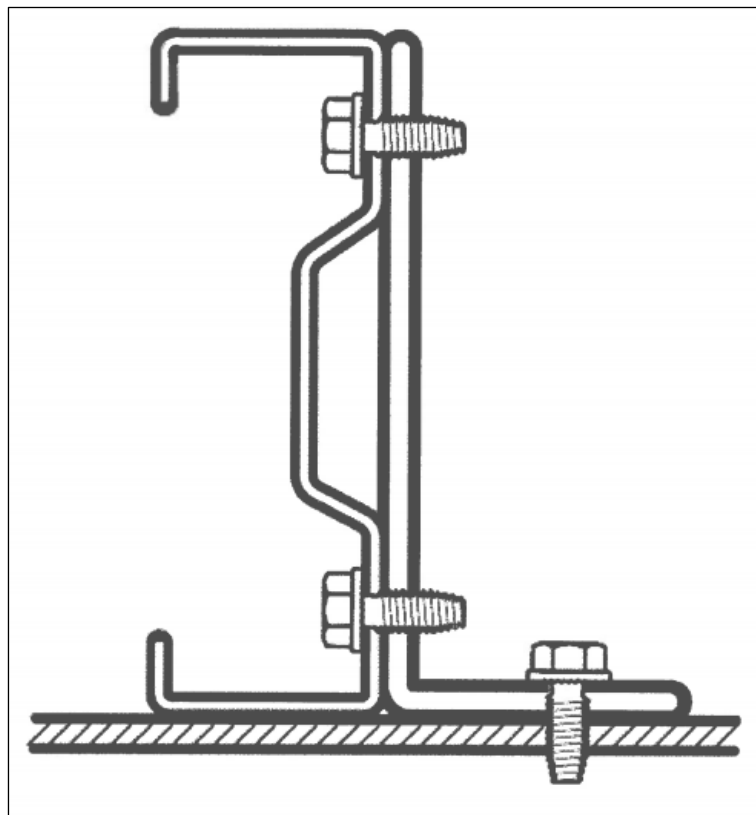
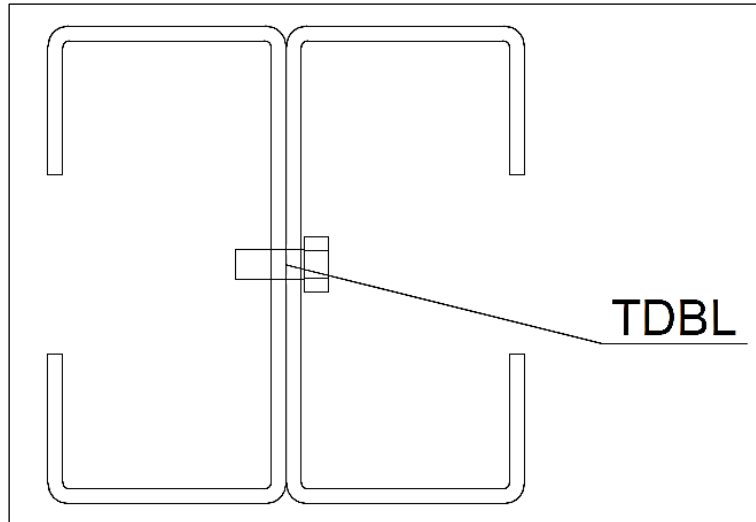

Fasteners for connection of steel structural members in steel and high bay warehouse structures

Application examples

Annex 3

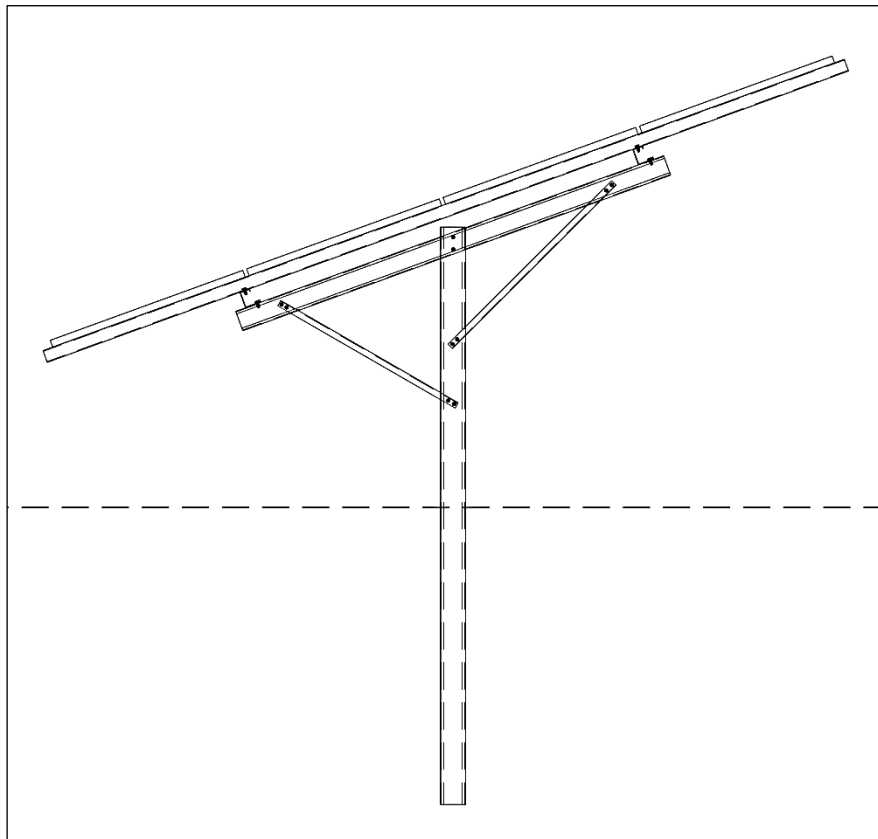
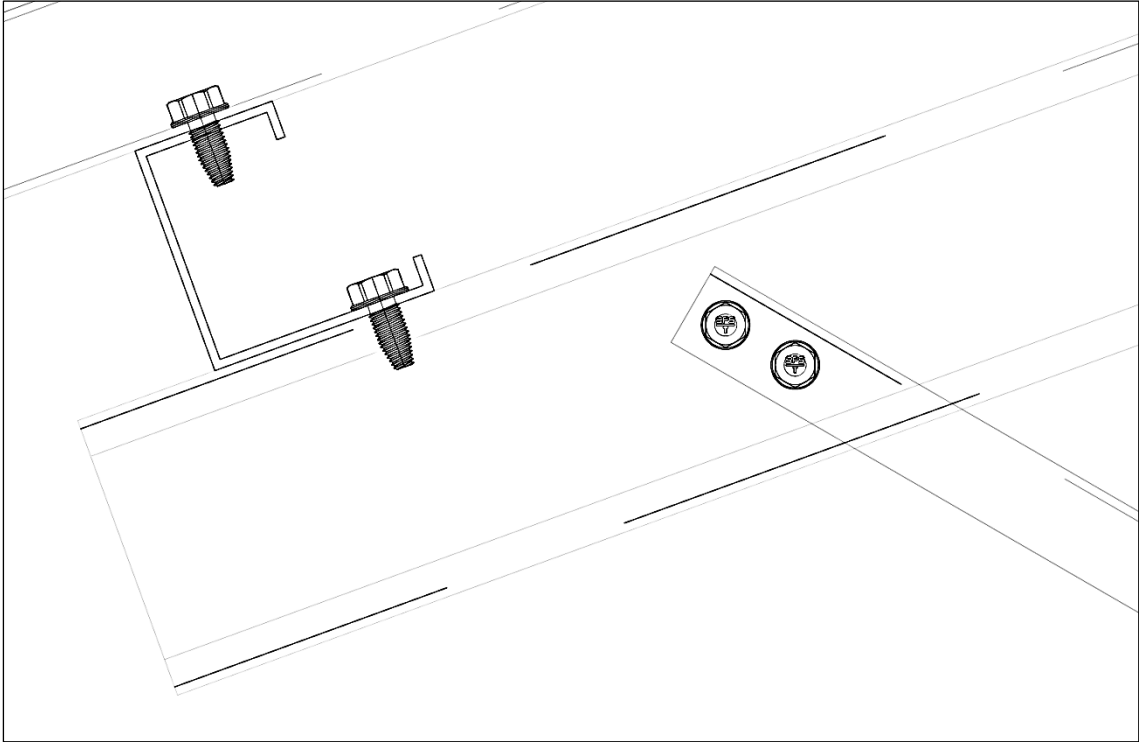

Fasteners for connection of steel structural members in steel and high bay warehouse structures

Application examples

Annex 4

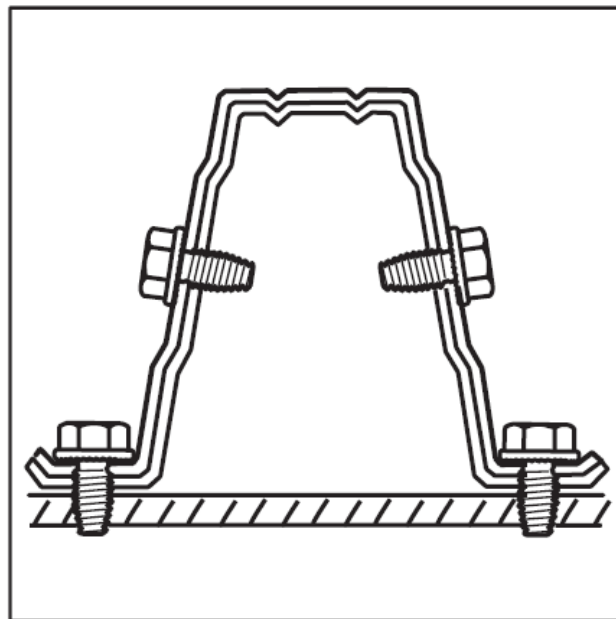
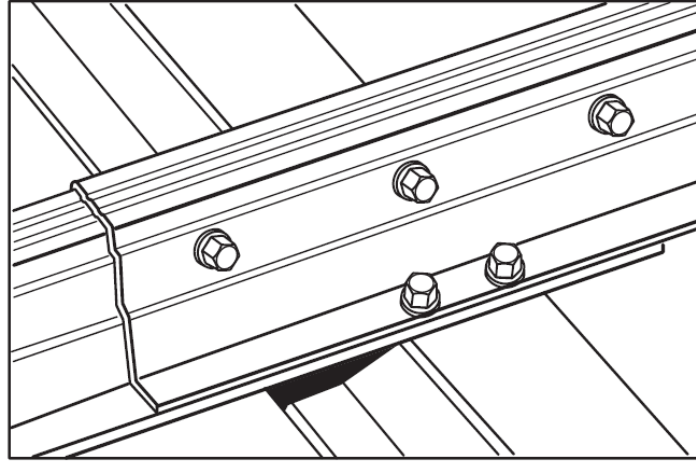

Fasteners for connection of steel structural members in steel and high bay warehouse structures

Application examples

Annex 5

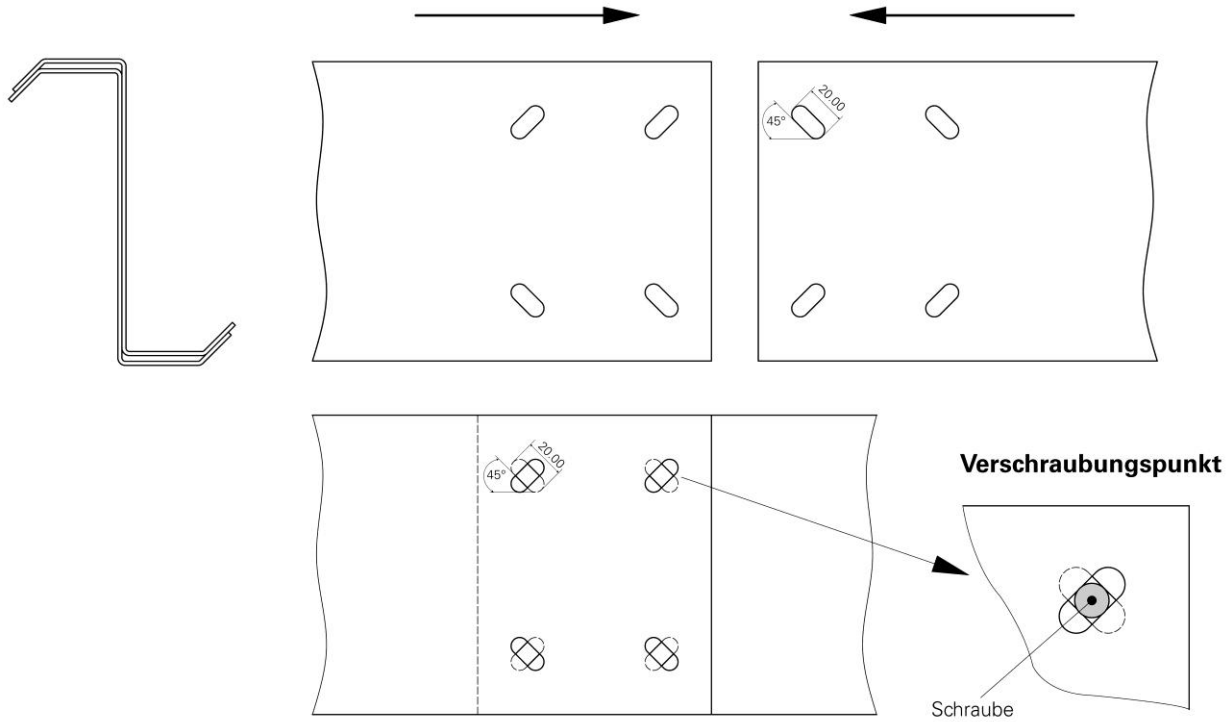

Verschraubungspunkt = screwing point
 Schraube = screw

Fasteners for connection of steel structural members in steel and high bay warehouse structures

Application example for screw TDBL-T-10.6 x L

Annex 6

Connection with single plate

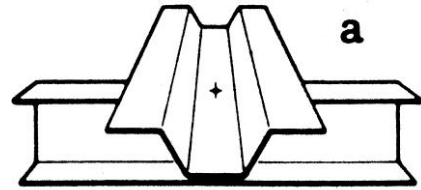

Connection with longitudinal joint

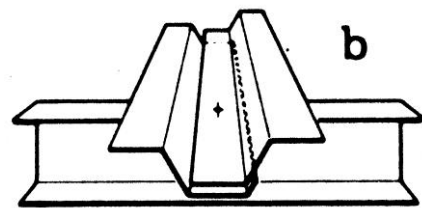

Connection with transverse joint

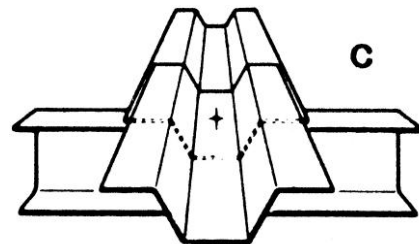

Connection with longitudinal and transverse joint

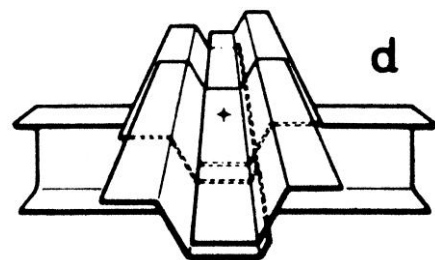

Fasteners for connection of steel structural members in steel and high bay warehouse structures

Fastener types

Annex 7

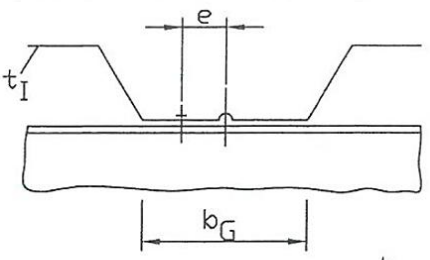
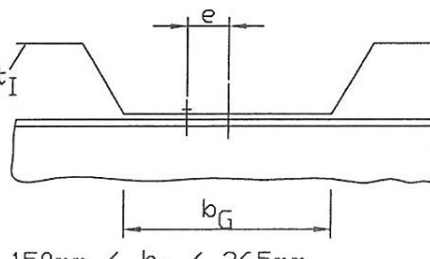
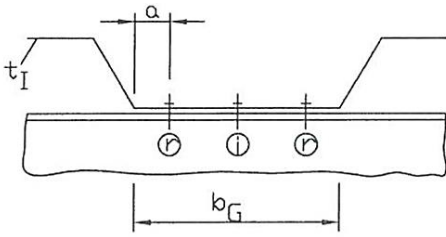
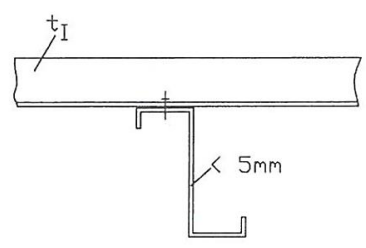
Case of application	Reduction factor for $t_1 < 1.25 \text{ mm}$						
 <p> $b_G \leq 150 \text{ mm}$ $e > \frac{b_G}{4}$ </p>	<p>0,9</p>						
 <p> $150 \text{ mm} < b_G \leq 265 \text{ mm}$ $0 < e \leq b_G/2$ </p>	<p>0,5</p>						
 <p> Bei $b_G > 265 \text{ mm}$ sind mindestens zwei Verbindungselemente erforderlich </p>	<p>für</p> <table style="width: 100%; border: none;"> <tr> <td style="text-align: center;">(i)</td> <td style="text-align: right;">0,0</td> </tr> <tr> <td style="text-align: center;">(r) $a \leq 75 \text{ mm}$</td> <td style="text-align: right;">0,7</td> </tr> <tr> <td style="text-align: center;">(r) $a > 75 \text{ mm}$</td> <td style="text-align: right;">0,35</td> </tr> </table>	(i)	0,0	(r) $a \leq 75 \text{ mm}$	0,7	(r) $a > 75 \text{ mm}$	0,35
(i)	0,0						
(r) $a \leq 75 \text{ mm}$	0,7						
(r) $a > 75 \text{ mm}$	0,35						
 <p>Dünnwandige, unsymmetrische Unterkonstruktion</p>	<p>0,7</p>						

* At least 2 fasteners are required with $b_G > 265 \text{ mm}$. ** Thin-walled asymmetrical supporting member *** für = for

Fasteners for connection of steel structural members in steel and high bay warehouse structures	Annex 8
Reduction factors for specific cases of application	

Table 1: Thread forming screws TDBL 13.4 x L, application in connections subject exclusively to shear force, e.g. high bay warehouse structures

Screw	Component I (component to be fastened)	Component II (supporting element)	Boundary conditions	Annex
	S235 through S355 in accordance with DIN EN 10025-2, S280GD through S450GD and HX300LAD through HX460LAD in accordance with DIN EN 10346			
TDBL-T-13.4xL	$1.00 \text{ mm} \leq t_I \leq 4.00 \text{ mm}$ pre-drilling diameter: 12.5 mm	$2.50 \text{ mm} \leq t_{II} \leq 6.00 \text{ mm}$ pre-drilling diameter: 12.5 mm	$t_I \leq t_{II}$	12
			$5.0 \text{ mm} \leq t_I + t_{II} \leq 8.0 \text{ mm}$	13
	$1.00 \text{ mm} \leq t_I \leq 4.00 \text{ mm}$ pre-drilling diameter: 13.0 mm	$t_{II} \geq 5.00 \text{ mm}$ pre-drilling diameter: 13.0 mm	$6.0 \text{ mm} \leq t_I + t_{II} \leq 10.0$ mm	14 15
TDBLF-T-13.4xL	$1.00 \text{ mm} \leq t_I \leq 3.00 \text{ mm}$ pre-drilling diameter: 12.5 mm	$1.50 \text{ mm} \leq t_{II} \leq 6.00 \text{ mm}$ pre-drilling diameter: 12.5 mm	$3.0 \leq t_I + t_{II} \leq 8.5 \text{ mm}$	16
			$t_I \leq t_{II}$ if $t_{II} > 2.0 \text{ mm}$	17

Table 2: Thread forming screws TDBL 13.4 x L, application in connections subject to a combination of tension and shear force or exclusively to shear force

Screw	Component I (component to be fastened)	Component II (supporting element)	Boundary conditions	Annex
	S235 through S355 in accordance with DIN EN 10025-2, S280GD through S450GD and HX300LAD through HX460LAD in accordance with DIN EN 10346			
TDBL-T-13.4xL or TDBLF-T-13.4xL	$5.00 \text{ mm} \leq t_I \leq 17.00 \text{ mm}$ pre-drilling diameter: 15.0 mm	$3.00 \text{ mm} \leq t_{II} \leq 5.00 \text{ mm}$ pre-drilling diameter: 12.5 mm	$t_I + t_{II} \leq 20.0 \text{ mm}$	18
		$5.00 \text{ mm} < t_{II} \leq 15.00 \text{ mm}$ pre-drilling diameter: 13.0 mm		19
TDBL-T-13.4xL	$1.00 \text{ mm} \leq t_I \leq 4.00 \text{ mm}$ pre-drilling diameter: 12.5 mm	$2.50 \text{ mm} \leq t_{II} \leq 6.00 \text{ mm}$ pre-drilling diameter: 12.5 mm	$t_I \leq t_{II}$	20
			$5.0 \leq t_I + t_{II} \leq 8.0 \text{ mm}$	21
	$1.00 \text{ mm} \leq t_I \leq 4.00 \text{ mm}$ pre-drilling diameter: 13.0 mm	$5.00 \text{ mm} \leq t_{II} \leq 19.00 \text{ mm}$ pre-drilling diameter: 13.0 mm	$t_I \leq t_{II}$	22
		$6.0 \leq t_I + t_{II} \leq 20.0 \text{ mm}$	23	
TDBLF-T-13.4xL	$1.00 \text{ mm} \leq t_I \leq 3.00 \text{ mm}$ pre-drilling diameter: 12.5 mm	$1.50 \text{ mm} \leq t_{II} \leq 6.00 \text{ mm}$ pre-drilling diameter: 12.5 mm	$3.0 \leq t_I + t_{II} \leq 8.0 \text{ mm}$	24
			$t_I \leq t_{II}$ if $t_{II} > 2.0 \text{ mm}$	

Fasteners for connection of steel structural members in steel and high bay warehouse structures

Screws TDBL-T-13.4xL and TDBLF-T-13.4xL

Annex 9

Table 3: Thread forming screws TDBL 10.6 x L, application in connections subject to a combination of tension and shear force or exclusively to shear force

Screw	Component I (component to be fastened)	Component II (supporting element)	Boundary conditions	Annex
	S235 through S355 in accordance with DIN EN 10025-2, S280GD through S450GD and HX300LAD through HX460LAD in accordance with DIN EN 10346			
TDBL-T-10.6xL or TDBLF-T-10.6xL	$5.00 \text{ mm} \leq t_i \leq 17.00 \text{ mm}$ pre-drilling diameter: 12.0 mm	$3.00 \text{ mm} \leq t_{II} \leq 15.00 \text{ mm}$ pre-drilling diameter: 10.0 mm	$t_i + t_{II} \leq 20.0 \text{ mm}$	25
				26
TDBL-T-10.6xL	$2 \times 0.88 \text{ mm} \leq t_i \leq 2 \times 2.00 \text{ mm}$ pre-drilling diameter: 10.0 mm	$t_{II} \geq 3.00 \text{ mm}$ pre-drilling diameter: 10.0 mm	$t_i + t_{II} \leq 20.0 \text{ mm}$	27
				28
	$2 \times 0.88 \text{ mm} \leq t_i \leq 2 \times 2.00 \text{ mm}$ slotted hole 8.5 mm x 28.5 mm	$t_{II} \geq 3.00 \text{ mm}$ pre-drilling diameter: 10.0 mm	$t_i + t_{II} \leq 20.0 \text{ mm}$	29
	$0.88 \text{ mm} \leq t_i \leq 4.00 \text{ mm}$ slotted hole 8.5 mm x 28.5 mm	$1.00 \text{ mm} \leq t_{II} \leq 3.00 \text{ mm}$ pre-drilling diameter: 9.0 mm	$t_i + t_{II} \leq 20.0 \text{ mm}$	30
		$t_{II} \geq 3.00 \text{ mm}$ pre-drilling diameter: 10.0 mm		31
	$1.00 \text{ mm} \leq t_i \leq 4.00 \text{ mm}$ pre-drilling diameter: 9.0 mm	$1.00 \text{ mm} \leq t_{II} \leq 2.00 \text{ mm}$ pre-drilling diameter: 9.0 mm	$t_i \leq t_{II}$	32
	$1.00 \text{ mm} \leq t_i \leq 4.00 \text{ mm}$ pre-drilling diameter: 10.0 mm	$3.00 \text{ mm} \leq t_{II} \leq 15.00 \text{ mm}$ pre-drilling diameter: 10.0 mm		33
$1.00 \text{ mm} \leq t_i \leq 3.00 \text{ mm}$ see Annex	$1.00 \text{ mm} \leq t_{II} \leq 3.00 \text{ mm}$ see Annex	$t_i \leq t_{II}$	34	
			35	

Fasteners for connection of steel structural members in steel and high bay warehouse structures

Annex 10

Screws TDBL-T-10.6xL and TDBLF-T-10.6xL

Table 4: Thread forming screws TDBL 8.6 x L, application in connections subject to a combination of tension and shear force or exclusively to shear force

Screw	Component I (component to be fastened)	Component II (supporting element)	Boundary conditions	Annex
	S235 through S355 in accordance with DIN EN 10025-2, S280GD through S450GD and HX300LAD through HX460LAD in accordance with DIN EN 10346			
TDBL-T-8.6xL	0.88 mm ≤ t _I ≤ 3.00 mm pre-drilling diameter: 7.5 mm	0.88 mm ≤ t _{II} ≤ 3.00 mm pre-drilling diameter: 7.5 mm	t _I ≤ t _{II}	36
	0.88 mm ≤ t _I ≤ 3.00 mm pre-drilling diameter: 8.0 mm	t _{II} ≥ 3.00 mm pre-drilling diameter: 8.0 mm		37
	2 x 0.88 mm ≤ t _I ≤ 2 x 2.00 mm pre-drilling diameter: 8.0 mm	t _{II} ≥ 3.00 mm pre-drilling diameter: 8.0 mm	-	38
	0.88 mm ≤ t _I ≤ 2.00 mm slotted hole 6.5 mm x 10.0 mm	0.88 mm ≤ t _{II} ≤ 3.00 mm pre-drilling diameter: 7.5 mm	t _I ≤ t _{II}	39
		t _{II} ≥ 3.00 mm pre-drilling diameter: 8.0 mm		40
	2 x 0.88 mm ≤ t _I ≤ 2 x 2.00 mm slotted hole 6.5 mm x 10.0 mm	t _{II} ≥ 3.00 mm pre-drilling diameter: 8.0 mm	-	41
	0.88 mm ≤ t _I ≤ 2.00 mm slotted hole 6.5 mm x 10.0 mm	t _{II} ≥ 0.88 mm slotted hole 6.5 mm x 10.0 mm	t _I ≤ t _{II}	42
				43
2 x 0.88 mm ≤ t _I ≤ 2 x 2.00 mm slotted hole 6.5 mm x 10.0 mm	t _{II} ≥ 3.00 mm slotted hole 6.5 mm x 10.0 mm	-	44	

Fasteners for connection of steel structural members in steel and high bay warehouse structures

Screws TDBL-T-8.6xL and TDBLF-T-8.6xL

Annex 11

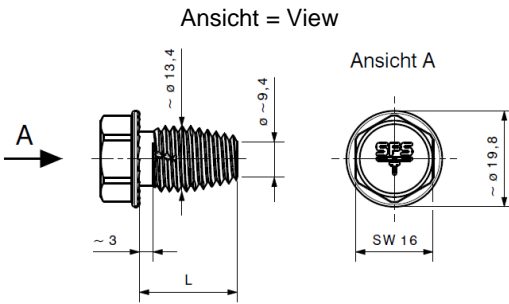
<p style="text-align: center;">Ansicht = View</p> 	<p>Materials</p> <p>Screw: Carbon steel tempered and coated</p> <p>Component I: S235 through S275 – EN 10025-2 S280GD through S350GD – EN 10346 HX300LAD through HX380LAD – EN 10346</p> <p>Component II: S235 through S275 – EN 10025-2 S280GD through S350GD – EN 10346 HX300LAD through HX380LAD – EN 10346</p> <p>Pre-drilling diameter</p> <p>Component I: $d_{pd,I} = 12.5 \text{ mm}$ Component II: see table</p>
---	--

		$t_{II} \text{ [mm]}$						
		2.50	3.00	3.50	4.00	5.00	6.00	
		$d_{pd,II} = 12.5 \text{ mm}$						
$V_{R,k} \text{ [kN]}$	1.00	-	-	-	7.83	7.94	7.94	
	1.13	-	-	-	9.93	9.41	9.41	
	1.25	-	-	-	9.96	10.77	10.77	
	1.50	-	-	13.60	13.60	13.60	13.60	
	1.75	-	-	12.92	13.97	16.07	16.07	
	$t_I \text{ [mm]}$	2.00	-	14.85	15.62	16.59	18.53	18.53
		2.50	13.82	15.42	17.02	18.61	21.81	-
3.00		-	18.28	19.98	21.69	25.09	-	
4.00		-	-	-	21.78	-	-	

Further specifications:

- For t_I and t_{II} made of S275, S320GD, S350GD, HX340LAD or HX380LAD with $R_{m,min} \geq 390 \text{ N/mm}^2$, the values may be increased by 8.3%.

Fasteners for connection of steel structural members in steel and high bay warehouse structures

TDBL-T-13.4 x L

Annex 12

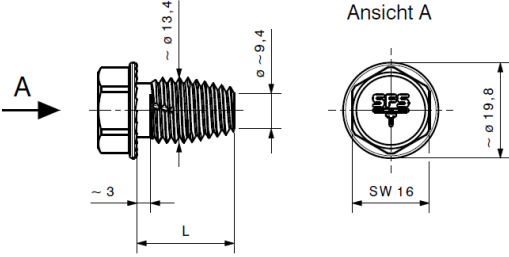
<p style="text-align: center;">Ansicht = View</p> 	<p>Materials</p> <p>Screw: Carbon steel tempered and coated</p> <p>Component I: S355 – EN 10025-2 S390GD through S450GD – EN 10346 HX420LAD through HX460LAD – EN 10346</p> <p>Component II: S355 – EN 10025-2 S390GD through S450GD – EN 10346 HX420LAD through HX460LAD – EN 10346</p> <p>Pre-drilling diameter</p> <p>Component I: $d_{pd,I} = 12.5 \text{ mm}$ Component II: see table</p>
---	---

		$t_{II} \text{ [mm]}$						
		2.50	3.00	3.50	4.00	5.00	6.00	
		$d_{pd,II} = 12.5 \text{ mm}$						
$V_{R,k} \text{ [kN]}$	1.00	-	-	-	8.48	8.60	8.60	
	1.13	-	-	-	9.67	10.19	10.19	
	1.25	-	-	-	10.79	11.66	11.66	
	1.50	-	-	14.73	14.73	14.73	14.73	
	1.75	-	-	13.99	15.13	17.40	17.40	
	$t_I \text{ [mm]}$	2.00	-	15.87	16.92	17.97	20.07	20.07
		2.50	17.66	19.71	21.75	23.78	27.87	-
3.00		-	23.36	25.53	27.72	32.07	-	
4.00		-	-	-	27.83	-	-	

No further specifications.

Fasteners for connection of steel structural members in steel and high bay warehouse structures	Annex 13
TDBL-T-13.4 x L	

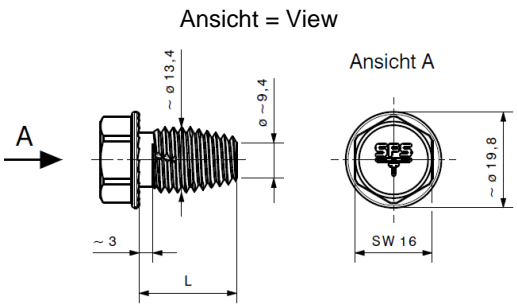
<p>Ansicht = View</p> 	<p>Materials</p> <p>Screw: Carbon steel tempered and coated</p> <p>Component I: S235 through S275 – EN 10025-2 S280GD through S350GD – EN 10346 HX300LAD through HX380LAD – EN 10346</p> <p>Component II: S235 through S275 – EN 10025-2 S280GD through S350GD – EN 10346 HX300LAD through HX380LAD – EN 10346</p>
	<p><u>pre-drilling diameter</u></p> <p>Component I: $d_{pd,I} = 13.0 \text{ mm}$ Component II: see table</p>

		$t_{II} \text{ [mm]}$						
		2.50	3.00	3.50	4.00	5.00	6.00	
		$d_{pd,II} = 13.0 \text{ mm}$						
$V_{R,k} \text{ [kN]}$	$t_I \text{ [mm]}$	1.00	-	-	-	-	7.94	7.94
		1.13	-	-	-	-	9.41	9.41
		1.25	-	-	-	-	10.77	10.77
		1.50	-	-	-	-	13.60	13.60
		1.75	-	-	-	-	16.07	16.07
		2.00	-	-	-	-	18.53	18.53
		2.50	-	-	-	-	21.81	21.81
		3.00	-	-	-	-	25.09	25.09
	4.00	-	-	-	-	25.09	25.09	

Further specifications:

- For t_I and t_{II} made of S275, S320GD, S350GD, HX340LAD or HX380LAD with $R_{m,min} \geq 390 \text{ N/mm}^2$, the values may be increased by 8.3%.

Fasteners for connection of steel structural members in steel and high bay warehouse structures

TDBL-T-13.4 x L

Annex 14

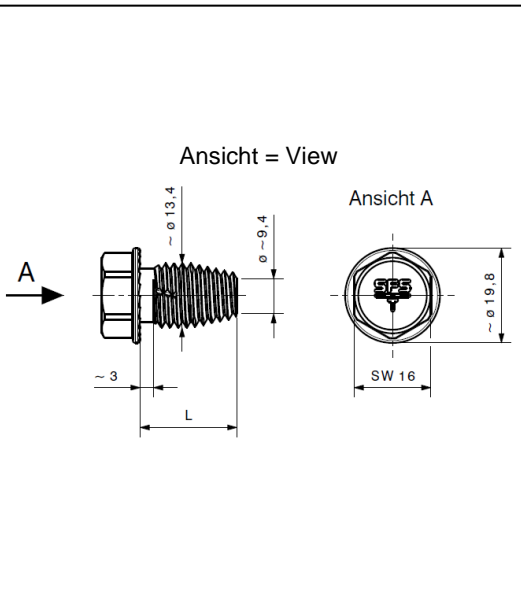

Materials

Screw: Carbon steel
 tempered and coated

Component I: S355 – EN 10025-2
 S390GD through S450GD – EN 10346
 HX420LAD through HX460LAD – EN 10346

Component II: S355 – EN 10025-2
 S390GD through S450GD – EN 10346
 HX420LAD through HX460LAD – EN 10346

pre-drilling diameter

Component I: $d_{pd,I} = 13.0 \text{ mm}$
 Component II: see table

		$t_{II} \text{ [mm]}$					
		2.50	3.00	3.50	4.00	5.00	6.00
		$d_{pd,II} = 13.0 \text{ mm}$					
$V_{R,k} \text{ [kN]}$ $t_I \text{ [mm]}$	1.00	-	-	-	-	8.60	8.60
	1.13	-	-	-	-	10.19	10.19
	1.25	-	-	-	-	11.66	11.66
	1.50	-	-	-	-	14.73	14.73
	1.75	-	-	-	-	17.40	17.40
	2.00	-	-	-	-	20.07	20.07
	2.50	-	-	-	-	27.87	27.87
	3.00	-	-	-	-	32.07	32.07
	4.00	-	-	-	-	32.07	32.07

No further specifications.

Fasteners for connection of steel structural members in steel and high bay warehouse structures

TDBL-T-13.4 x L

Annex 15

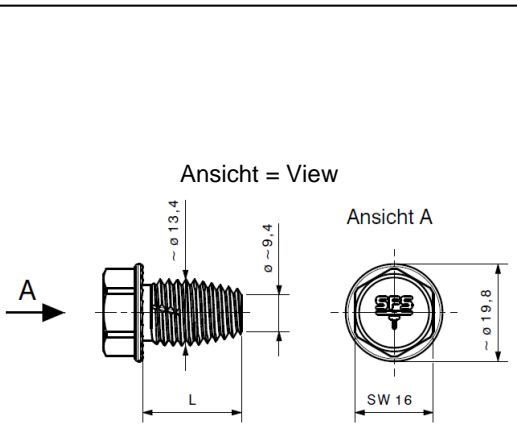

Materials

Screw: Carbon steel
 tempered and coated

Component I: S235 through S275 – EN 10025-2
 S280GD through S350GD – EN 10346
 HX300LAD through HX380LAD – EN 10346

Component II: S235 through S275 – EN 10025-2
 S280GD through S350GD – EN 10346
 HX300LAD through HX380LAD – EN 10346

pre-drilling diameter

Component I: $d_{pd,I} = 12.5 \text{ mm}$
 Component II: see table

		$t_{II} \text{ [mm]}$									
		1.50	1.75	2.00	2.50	3.00	3.50	4.00	5.00	6.00	
		$d_{pd,II} = 12.5 \text{ mm}$									
$V_{R,k} \text{ [kN]}$	1.00	-	-	7.61	7.67	7.72	7.78	7.83	7.94	7.94	
	1.13	-	-	7.98	8.22	8.46	8.70	8.93	9.41	9.41	
	1.25	-	7.12	8.33	8.74	9.14	9.55	9.96	10.77	10.77	
	1.50	5.90	7.48	9.05	10.57	12.08	13.60	13.60	13.60	13.60	
	1.75	5.90	7.83	9.76	10.81	11.86	12.92	13.97	16.07	16.07	
	$t_I \text{ [mm]}$	2.00	5.90	8.19	10.48	12.57	14.65	15.62	16.59	18.53	18.53
		2.50	-	-	-	12.57	14.65	15.62	16.59	18.53	18.53
		3.00	-	-	-	-	14.65	15.62	16.59	18.53	-
4.00		-	-	-	-	-	-	-	-	-	

Further specifications:

- F- For t_I and t_{II} made of S275, S320GD, S350GD, HX340LAD or HX380LAD with $R_{m,min} \geq 390 \text{ N/mm}^2$, the values may be increased by 8.3%.

Fasteners for connection of steel structural members in steel and high bay warehouse structures

TDBLF-T-13.4 x L

Annex 16

	<p>Materials</p> <p>Screw: Carbon steel tempered and coated</p> <p>Component I: S355 – EN 10025-2 S390GD through S450GD – EN 10346 HX420LAD through HX460LAD – EN 10346</p> <p>Component II: S355 – EN 10025-2 S390GD through S450GD – EN 10346 HX420LAD through HX460LAD – EN 10346</p> <p>pre-drilling diameter</p> <p>Component I: $d_{pd,I} = 12.5 \text{ mm}$ Component II: see table</p>
--	---

		$t_{II} \text{ [mm]}$									
		1.50	1.75	2.00	2.50	3.00	3.50	4.00	5.00	6.00	
		$d_{pd,II} = 12.5 \text{ mm}$									
$V_{R,k} \text{ [kN]}$	1.00	-	-	8.24	8.31	8.36	8.43	8.48	8.60	8.60	
	1.13	-	-	8.64	8.90	9.16	9.42	9.67	10.19	10.19	
	1.25	-	7.71	9.02	9.47	9.90	10.34	10.79	11.66	11.66	
	1.50	6.39	8.10	9.80	11.45	13.08	14.73	14.73	14.73	14.73	
	1.75	6.39	8.48	10.57	11.71	12.84	13.99	15.13	17.40	17.40	
	$t_I \text{ [mm]}$	2.00	6.39	8.87	11.35	13.61	15.87	16.92	17.97	20.07	20.07
		2.50	-	-	-	13.61	15.87	16.92	17.97	20.07	20.07
		3.00	-	-	-	-	15.87	16.92	17.97	20.07	-
4.00		-	-	-	-	-	-	-	-	-	

No further specifications.

Fasteners for connection of steel structural members in steel and high bay warehouse structures

TDBLF-T-13.4 x L

Annex 17

Materials

Screw: Carbon steel
tempered and coated

Component I: S235 through S275 – EN 10025-2
S280GD through S350GD – EN 10346
HX300LAD through HX380LAD – EN 10346

Component II: S235 through S275 – EN 10025-2
S280GD through S350GD – EN 10346
HX300LAD through HX380LAD – EN 10346

pre-drilling diameter

Component I: $d_{pd,I} = 15.0 \text{ mm}$
Component II: $d_{pd,II}$ see table

		$t_{II} \text{ [mm]}$											
		3.00	3.50	4.00	4.50	5.00	6.00	7.00	8.00	10.00	12.00	15.00	
		$d_{pd,II} = 12.5 \text{ mm}$					$d_{pd,II} = 13.0 \text{ mm}$						
$V_{R,k} \text{ [kN]}$	5.00	10.82	16.10	21.37	21.93	22.48	22.48	22.48	22.48	22.48	22.48	22.48	
	6.00	10.82	16.10	21.37	21.93	22.48	23.45	23.45	23.45	23.45	23.45	-	
	7.00	10.82	16.10	21.37	21.93	22.48	23.45	23.88	23.88	23.88	23.88	-	
	8.00	10.82	16.10	21.37	21.93	22.48	23.45	23.88	24.30	24.30	24.30	-	
	$t_I \text{ [mm]}$	10.00	10.82	16.10	21.37	21.93	22.48	23.45	23.88	24.30	32.09	-	-
		12.00	10.82	16.10	21.37	21.93	22.48	23.45	23.88	24.30	-	-	-
		17.00	10.82	-	-	-	-	-	-	-	-	-	-
$N_{R,k} \text{ [kN]}$	5.00	9.33	11.22	13.10	15.57	18.03	18.97	18.97	18.97	18.97	18.97	18.97	
	6.00	9.33	11.22	13.10	15.57	18.03	23.26	23.26	23.26	23.26	23.26	-	
	7.00	9.33	11.22	13.10	15.57	18.03	23.30	24.41	24.41	24.41	24.41	-	
	8.00	9.33	11.22	13.10	15.57	18.03	23.30	25.55	25.55	25.55	25.55	-	
	$t_I \text{ [mm]}$	10.00	9.33	11.22	13.10	15.57	18.03	23.30	26.35	29.39	34.79	-	-
		12.00	9.33	11.22	13.10	15.57	18.03	23.30	26.35	29.39	-	-	-
		17.00	9.33	-	-	-	-	-	-	-	-	-	-

Further specifications:

- For t_I and t_{II} made of S275, S320GD, S350GD, HX340LAD or HX380LAD with $R_{m,min} \geq 390 \text{ N/mm}^2$, the values may be increased by 8.3%.

Fasteners for connection of steel structural members in steel and high bay warehouse structures

TDBL-T-13.4 x L
TDBLF-T-13.4 x L

Annex 18

<p style="text-align: center;">Ansicht = view</p>	<p><u>Materials</u></p> <p>Screw: Carbon steel tempered and coated</p> <p>Component I: S355 – EN 10025-2 S390GD through S450GD – EN 10346 HX420LAD through HX460LAD – EN 10346</p> <p>Component II: S355 – EN 10025-2 S390GD through S450GD – EN 10346 HX420LAD through HX460LAD – EN 10346</p>
	<p><u>pre-drilling diameter</u></p> <p>Component I: $d_{pd,I} = 15.0 \text{ mm}$ Component II: $d_{pd,II}$ see table</p>

		$t_{II} \text{ [mm]}$											
		3.00	3.50	4.00	4.50	5.00	6.00	7.00	8.00	10.00	12.00	15.00	
		$d_{pd,II} = 12.5 \text{ mm}$					$d_{pd,II} = 13.0 \text{ mm}$						
$V_{R,k} \text{ [kN]}$	5.00	13.83	20.57	27.31	28.02	28.72	28.72	28.72	28.72	28.72	28.72	28.72	
	6.00	13.83	20.57	27.31	28.02	28.72	29.96	29.96	29.96	29.96	29.96	-	
	7.00	13.83	20.57	27.31	28.02	28.72	29.96	30.51	30.51	30.51	30.51	-	
	8.00	13.83	20.57	27.31	28.02	28.72	29.96	30.51	31.05	31.05	31.05	-	
	$t_i \text{ [mm]}$	10.00	13.83	20.57	27.31	28.02	28.72	29.96	30.51	31.05	41.00	-	-
		12.00	13.83	20.57	27.31	28.02	28.72	29.96	30.51	31.05	-	-	-
		17.00	13.83	-	-	-	-	-	-	-	-	-	-
$N_{R,k} \text{ [kN]}$	5.00	12.91	15.53	18.13	21.54	24.96	32.24	36.47	39.38	39.38	39.38	39.38	
	6.00	12.91	15.53	18.13	21.54	24.96	32.24	36.47	40.67	48.27	48.27	-	
	7.00	12.91	15.53	18.13	21.54	24.96	32.24	36.47	40.67	50.65	50.65	-	
	$t_i \text{ [mm]}$	8.00	12.91	15.53	18.13	21.54	24.96	32.24	36.47	40.67	55.03	55.03	-
		10.00	12.91	15.53	18.13	21.54	24.96	32.24	36.47	40.67	55.03	-	-
		12.00	12.91	15.53	18.13	21.54	24.96	32.24	36.47	40.67	-	-	-
		17.00	12.91	-	-	-	-	-	-	-	-	-	-

No further specifications.

Fasteners for connection of steel structural members in steel and high bay warehouse structures

TDBL-T-13.4 x L
TDBLF-T-13.4 x L

Annex 19

<p>Ansicht = view</p>	<p>Materials</p> <p>Screw: Carbon steel tempered and coated</p> <p>Component I: S235 through S275 – EN 10025-2 S280GD through S350GD – EN 10346 HX300LAD through HX380LAD – EN 10346</p> <p>Component II: S235 through S275 – EN 10025-2 S280GD through S350GD – EN 10346 HX300LAD through HX380LAD – EN 10346</p> <p>pre-drilling diameter</p> <p>Component I: $d_{pd,I} = 12.5 \text{ mm}$ Component II: $d_{pd,II}$ see table</p>
-----------------------	---

		$t_{II} \text{ [mm]}$								
		2.50	3.00	3.50	4.00	4.50	5.00	5.50	6.00	
		$d_{pd,II} = 12.5 \text{ mm}$								
$V_{R,k} \text{ [kN]}$	1.00	-	-	-	6.56	6.56	6.56	6.56	6.56	
	1.13	-	-	-	7.63	7.63	7.63	7.63	7.63	
	1.25	-	-	-	8.62	8.62	8.62	8.62	8.62	
	1.50	-	-	10.67	10.67	10.67	10.67	10.67	10.67	
	1.75	-	-	11.45	11.45	11.45	11.45	11.45	11.45	
	$t_I \text{ [mm]}$	2.00	-	12.22	12.22	12.22	12.22	12.22	12.22	12.22
		2.50	12.90	14.13	14.13	14.13	14.13	14.13	14.13	-
		3.00	-	16.04	16.04	16.04	16.04	16.04	-	-
		3.50	-	-	18.85	18.85	18.85	-	-	-
		4.00	-	-	-	21.66	-	-	-	-
$N_{R,k} \text{ [kN]}$	1.00	-	-	-	5.18	5.18	5.18	5.18	5.18	
	1.13	-	-	-	6.73	6.73	6.73	6.73	6.73	
	1.25	-	-	-	8.16	8.16	8.16	8.16	8.16	
	1.50	-	-	11.14	11.14	11.14	11.14	11.14	11.14	
	1.75	-	-	11.22	12.17	12.17	12.17	12.17	12.17	
	$t_I \text{ [mm]}$	2.00	-	9.33	11.22	13.10	13.19	13.19	13.19	13.19
		2.50	7.55	9.33	11.22	13.10	13.24	13.24	13.24	-
		3.00	-	9.33	11.22	13.10	13.29	13.29	-	-
		3.50	-	-	11.22	13.10	14.79	-	-	-
		4.00	-	-	-	13.10	-	-	-	-

Further specifications:

- For t_I and t_{II} made of S275, S320GD, S350GD, HX340LAD or HX380LAD with $R_{m,min} \geq 390 \text{ N/mm}^2$, the values may be increased by 8.3%.

Fasteners for connection of steel structural members in steel and high bay warehouse structures

TDBL-T-13.4 x L

Annex 20

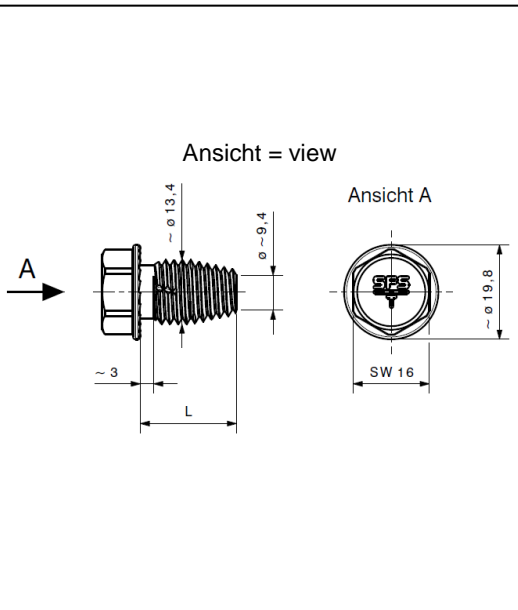

Materials

Screw: Carbon steel
tempered and coated

Component I: S355 – EN 10025-2
S390GD through S450GD – EN 10346
HX420LAD through HX460LAD – EN 10346

Component II: S355 – EN 10025-2
S390GD through S450GD – EN 10346
HX420LAD through HX460LAD – EN 10346

pre-drilling diameter

Component I: $d_{pd,I} = 12.5 \text{ mm}$
 Component II: $d_{pd,II}$ see table

		$t_{II} \text{ [mm]}$								
		2.50	3.00	3.50	4.00	4.50	5.00	5.50	6.00	
		$d_{pd,II} = 12.5 \text{ mm}$								
$V_{R,k} \text{ [kN]}$	1.00	-	-	-	7.11	7.11	7.11	7.11	7.11	
	1.13	-	-	-	8.27	8.27	8.27	8.27	8.27	
	1.25	-	-	-	9.34	9.34	9.34	9.34	9.34	
	1.50	-	-	11.56	11.56	11.56	11.56	11.56	11.56	
	1.75	-	-	12.40	12.40	12.40	12.40	12.40	12.40	
	$t_i \text{ [mm]}$	2.00	-	13.24	13.24	13.24	13.24	13.24	13.24	13.24
		2.50	16.48	18.06	18.06	18.06	18.06	18.06	18.06	-
		3.00	-	20.50	20.50	20.50	20.50	20.50	-	-
		3.50	-	-	24.09	24.09	24.09	-	-	-
4.00		-	-	-	27.68	-	-	-	-	
$N_{R,k} \text{ [kN]}$	1.00	-	-	-	5.61	5.61	5.61	5.61	5.61	
	1.13	-	-	-	7.29	7.29	7.29	7.29	7.29	
	1.25	-	-	-	8.84	8.84	8.84	8.84	8.84	
	1.50	-	-	12.07	12.07	12.07	12.07	12.07	12.07	
	1.75	-	-	12.16	13.18	13.18	13.18	13.18	13.18	
	$t_i \text{ [mm]}$	2.00	-	10.11	12.16	14.19	14.29	14.29	14.29	14.29
		2.50	9.65	11.92	14.34	16.74	16.92	16.92	16.92	-
		3.00	-	11.92	14.34	16.74	16.98	16.98	-	-
		3.50	-	-	14.34	16.74	18.90	-	-	-
4.00		-	-	-	16.74	-	-	-	-	

No further specifications.

Fasteners for connection of steel structural members in steel and high bay warehouse structures

TDBL-T-13.4 x L

Annex 21

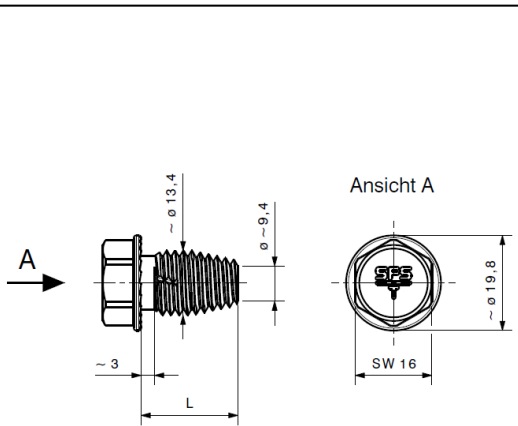

Ansicht = view

Materials

Screw: Carbon steel
tempered and coated

Component I: S235 through S275 – EN 10025-2
S280GD through S350GD – EN 10346
HX300LAD through HX380LAD – EN 10346

Component II: S235 through S275 – EN 10025-2
S280GD through S350GD – EN 10346
HX300LAD through HX380LAD – EN 10346

pre-drilling diameter

Component I: $d_{pd,I} = 13.0 \text{ mm}$
Component II: $d_{pd,II}$ see table

		$t_{II} \text{ [mm]}$									
		5.00	6.00	8.00	10.00	12.00	14.00	16.00	18.00	19.00	
		$d_{pd,II} = 13.0 \text{ mm}$									
$V_{R,k} \text{ [kN]}$	1.00	7.94	7.94	7.94	7.94	7.94	7.94	7.94	7.94	7.94	
	1.13	8.85	8.85	8.85	8.85	8.85	8.85	8.85	8.85	-	
	1.25	9.69	9.69	9.69	9.69	9.69	9.69	9.69	9.69	-	
	1.50	11.44	11.44	11.44	11.44	11.44	11.44	11.44	11.44	-	
	1.75	12.98	12.98	12.98	12.98	12.98	12.98	12.98	12.98	-	
	$t_I \text{ [mm]}$	2.00	14.51	14.51	14.51	14.51	14.51	14.51	14.51	14.51	-
		2.50	14.96	14.96	14.96	14.96	14.96	14.96	14.96	-	-
		3.00	15.41	15.41	15.41	15.41	15.41	15.41	15.41	-	-
		3.50	18.32	18.32	18.32	18.32	18.32	18.32	18.32	-	-
4.00		21.23	21.23	21.23	21.23	21.23	21.23	21.23	-	-	
$N_{R,k} \text{ [kN]}$	1.00	6.06	6.06	6.06	6.06	6.06	6.06	6.06	6.06	6.06	
	1.13	7.05	7.05	7.05	7.05	7.05	7.05	7.05	7.05	-	
	1.25	7.96	7.96	7.96	7.96	7.96	7.96	7.96	7.96	-	
	1.50	9.85	9.85	9.85	9.85	9.85	9.85	9.85	9.85	-	
	1.75	11.09	11.09	11.09	11.09	11.09	11.09	11.09	11.09	-	
	$t_I \text{ [mm]}$	2.00	12.33	12.33	12.33	12.33	12.33	12.33	12.33	12.33	-
		2.50	12.59	12.59	12.59	12.59	12.59	12.59	12.59	-	-
		3.00	12.84	12.84	12.84	12.84	12.84	12.84	12.84	-	-
		3.50	14.25	14.25	14.25	14.25	14.25	14.25	14.25	-	-
4.00		15.65	15.65	15.65	15.65	15.65	15.65	15.65	-	-	

Further specifications:

- F- For t_I and t_{II} made of S275, S320GD, S350GD, HX340LAD or HX380LAD with $R_{m,min} \geq 390 \text{ N/mm}^2$, the values may be increased by 8.3%.

Fasteners for connection of steel structural members in steel and high bay warehouse structures

TDBL-T-13.4 x L

Annex 22

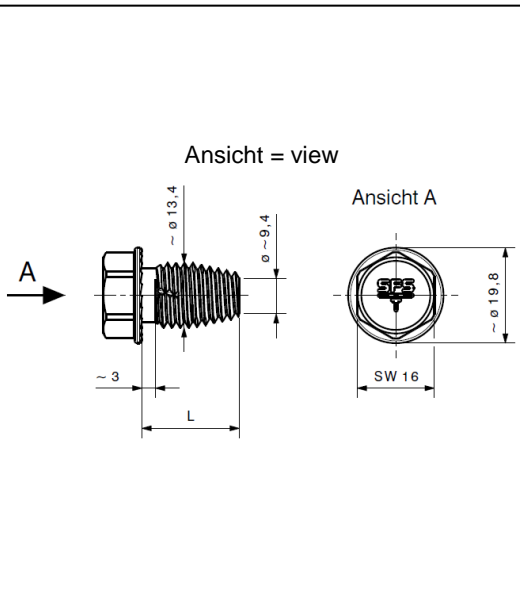

Materials

Screw: Carbon steel
tempered and coated

Component I: S355 – EN 10025-2
S390GD through S450GD – EN 10346
HX420LAD through HX460LAD – EN 10346

Component II: S355 – EN 10025-2
S390GD through S450GD – EN 10346
HX420LAD through HX460LAD – EN 10346

pre-drilling diameter

Component I: $d_{pd,I} = 13.0 \text{ mm}$
 Component II: $d_{pd,II}$ see table

		$t_{II} \text{ [mm]}$									
		5.00	6.00	8.00	10.00	12.00	14.00	16.00	18.00	19.00	
		$d_{pd,II} = 13.0 \text{ mm}$									
$V_{R,k} \text{ [kN]}$	1.00	9.32	9.32	9.32	9.32	9.32	9.32	9.32	9.32	9.32	
	1.13	10.38	10.38	10.38	10.38	10.38	10.38	10.38	10.38	-	
	1.25	11.36	11.36	11.36	11.36	11.36	11.36	11.36	11.36	-	
	1.50	13.42	13.42	13.42	13.42	13.42	13.42	13.42	13.42	-	
	1.75	15.23	15.23	15.23	15.23	15.23	15.23	15.23	15.23	-	
	$t_i \text{ [mm]}$	2.00	17.02	17.02	17.02	17.02	17.02	17.02	17.02	17.02	-
		2.50	20.70	20.70	20.70	20.70	20.70	20.70	20.70	-	-
		3.00	21.33	21.33	21.33	21.33	21.33	21.33	21.33	-	-
		3.50	25.35	25.35	25.35	25.35	25.35	25.35	25.35	-	-
4.00		29.38	29.38	29.38	29.38	29.38	29.38	29.38	-	-	
$N_{R,k} \text{ [kN]}$	1.00	6.57	6.57	6.57	6.57	6.57	6.57	6.57	6.57	6.57	
	1.13	7.64	7.64	7.64	7.64	7.64	7.64	7.64	7.64	-	
	1.25	8.62	8.62	8.62	8.62	8.62	8.62	8.62	8.62	-	
	1.50	10.67	10.67	10.67	10.67	10.67	10.67	10.67	10.67	-	
	1.75	12.01	12.01	12.01	12.01	12.01	12.01	12.01	12.01	-	
	$t_i \text{ [mm]}$	2.00	13.36	13.36	13.36	13.36	13.36	13.36	13.36	13.36	-
		2.50	16.09	16.09	16.09	16.09	16.09	16.09	16.09	-	-
		3.00	16.41	16.41	16.41	16.41	16.41	16.41	16.41	-	-
		3.50	18.21	18.21	18.21	18.21	18.21	18.21	18.21	-	-
4.00		20.00	20.00	20.00	20.00	20.00	20.00	20.00	-	-	

No further specifications.

Fasteners for connection of steel structural members in steel and high bay warehouse structures

TDBL-T-13.4 x L

Annex 23

	<p>Materials</p> <p>Screw: Carbon steel tempered and coated</p> <p>Component I: S235 through S355 – EN 10025-2 S280GD through S450GD – EN 10346 HX300LAD through HX460LAD – EN 10346</p> <p>Component II: S235 through S355 – EN 10025-2 S280GD through S450GD – EN 10346 HX300LAD through HX460LAD – EN 10346</p> <p>pre-drilling diameter</p> <p>Component I: $d_{pd,I} = 12.5 \text{ mm}$ Component II: $d_{pd,II}$ see table</p>
--	---

		$t_{II} \text{ [mm]}$									
		1.50	1.75	2.00	2.50	3.00	3.50	4.00	5.00	6.00	
		$d_{pd,II} = 12.5 \text{ mm}$									
$V_{R,k} \text{ [kN]}$	1.00	-	-	6.26 ^{a)}	6.26 ^{a)}	6.26 ^{a)}	6.26 ^{a)}	6.26 ^{a)}	6.26 ^{a)}	6.26 ^{a)}	
	1.13	-	-	6.26 ^{a)}	6.26 ^{a)}	6.26 ^{a)}	6.26 ^{a)}	6.26 ^{a)}	6.26 ^{a)}	6.26 ^{a)}	
	1.25	5.82 ^{a)}	6.26 ^{a)}	6.26 ^{a)}	6.26 ^{a)}	6.26 ^{a)}	6.26 ^{a)}	6.26 ^{a)}	6.26 ^{a)}	6.26 ^{a)}	
	1.50	6.03 ^{a)}	6.89 ^{a)}	7.74 ^{a)}	7.74 ^{a)}	7.74 ^{a)}	7.74 ^{a)}	7.74 ^{a)}	7.74 ^{a)}	7.74 ^{a)}	
	$t_I \text{ [mm]}$	1.75	6.03 ^{a)}	8.35 ^{a)}	9.21 ^{a)}	9.21 ^{a)}	9.21 ^{a)}	9.21 ^{a)}	9.21 ^{a)}	9.21 ^{a)}	9.21 ^{a)}
		2.00	6.03 ^{a)}	8.35 ^{a)}	10.69 ^{b)}	10.69 ^{b)}	10.69 ^{b)}	10.69 ^{b)}	10.69 ^{b)}	10.69 ^{b)}	10.69 ^{b)}
		2.50	-	-	-	10.69 ^{b)}	10.69 ^{b)}	10.69 ^{b)}	10.69 ^{b)}	10.69 ^{b)}	10.69 ^{b)}
3.00		-	-	-	-	10.69 ^{b)}	10.69 ^{b)}	10.69 ^{b)}	10.69 ^{b)}	-	
$N_{R,k} \text{ [kN]}$	1.00	-	-	5.01 ^{a)}	5.18 ^{a)}	5.18 ^{a)}	5.18 ^{a)}	5.18 ^{a)}	5.18 ^{a)}	5.18 ^{a)}	
	1.13	-	-	5.01 ^{b)}	6.73 ^{a)}	6.73 ^{a)}	6.73 ^{a)}	6.73 ^{a)}	6.73 ^{a)}	6.73 ^{a)}	
	1.25	3.11 ^{a)}	4.06 ^{a)}	5.01 ^{b)}	7.55 ^{a)}	8.16 ^{a)}	8.16 ^{a)}	8.16 ^{a)}	8.16 ^{a)}	8.16 ^{a)}	
	1.50	3.11 ^{a)}	4.06 ^{a)}	5.01 ^{b)}	7.55 ^{b)}	9.33 ^{b)}	11.14 ^{a)}	11.14 ^{a)}	11.14 ^{a)}	11.14 ^{a)}	
	$t_I \text{ [mm]}$	1.75	3.11 ^{a)}	4.06 ^{a)}	5.01 ^{b)}	7.55 ^{b)}	9.33 ^{b)}	11.22 ^{a)}	12.17 ^{a)}	12.17 ^{a)}	12.17 ^{a)}
		2.00	3.11 ^{a)}	4.06 ^{a)}	5.01 ^{b)}	7.55 ^{b)}	9.33 ^{b)}	11.22 ^{b)}	13.10 ^{b)}	13.19 ^{b)}	13.19 ^{b)}
		2.50	-	-	-	7.55 ^{b)}	9.33 ^{b)}	11.22 ^{b)}	13.10 ^{b)}	13.19 ^{b)}	13.19 ^{b)}
3.00		-	-	-	-	9.33 ^{b)}	11.22 ^{b)}	13.10 ^{b)}	13.19 ^{b)}	-	

Further specifications:

- For t_I and t_{II} made of S275, S320GD, S350GD, HX340LAD or HX380LAD with $R_{m,min} \geq 390 \text{ N/mm}^2$, the values may be increased by 8.3%.
- For t_I und t_{II} made of S355, S390GD, S420GD, S450GD, HX420LAD or HX460LAD with $R_{m,min} \geq 460 \text{ N/mm}^2$ the values marked with ^{a)} may be increased by 8.3% and the values marked with ^{b)} may be increased by 27.8%.

Fasteners for connection of steel structural members in steel and high bay warehouse structures

TDBLF-T-13.4 x L

Annex 24

Ansicht = view

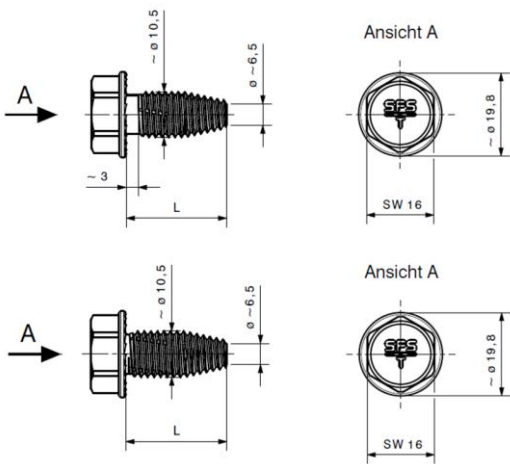

Materials

Screw: Carbon steel
 tempered and coated

Component I: S235 through S275 – EN 10025-2
 S280GD through S350GD – EN 10346
 HX300LAD through HX380LAD – EN 10346

Component II: S235 through S275 – EN 10025-2
 S280GD through S350GD – EN 10346
 HX300LAD through HX380LAD – EN 10346

pre-drilling diameter

Component I: $d_{pd,I} = 12.0 \text{ mm}$
 Component II: $d_{pd,II}$ see table

		$t_{II} \text{ [mm]}$								
		3.00	4.00	5.00	6.00	8.00	10.00	12.00	14.00	15.00
		$d_{pd,II} = 10.0 \text{ mm}$								
$V_{R,k} \text{ [kN]}$	5.00	11.62 ^{a)}	18.83 ^{a)}	26.04	26.04	26.04	26.04	26.04	26.04	26.04
	6.00	11.62 ^{a)}	18.83 ^{a)}	26.04	29.61	29.61	29.61	29.61	29.61	-
	8.00	11.62 ^{a)}	18.83 ^{a)}	26.04	29.61	31.09	31.09	31.09	-	-
	$t_I \text{ [mm]}$	10.00	11.62 ^{a)}	18.83 ^{a)}	26.04	29.61	31.09	31.09	-	-
	12.00	11.62 ^{a)}	18.83 ^{a)}	26.04	29.61	31.09	-	-	-	-
$N_{R,k} \text{ [kN]}$	5.00	7.21 ^{a)}	11.76 ^{a)}	15.64 ^{a)}	22.28 ^{a)}	22.72 ^{a)}	22.72 ^{a)}	22.72 ^{a)}	22.72 ^{a)}	22.72 ^{a)}
	6.00	7.21 ^{a)}	11.76 ^{a)}	15.64 ^{a)}	22.28 ^{a)}	28.73 ^{a)}	28.73 ^{a)}	28.73 ^{a)}	28.73 ^{a)}	-
	8.00	7.21 ^{a)}	11.76 ^{a)}	15.64 ^{a)}	22.28 ^{a)}	29.58 ^{a)}	40.55	40.55	-	-
	$t_I \text{ [mm]}$	10.00	7.21 ^{a)}	11.76 ^{a)}	15.64 ^{a)}	22.28 ^{a)}	29.58 ^{a)}	40.55	-	-
	12.00	7.21 ^{a)}	11.76 ^{a)}	15.64 ^{a)}	22.28 ^{a)}	29.58 ^{a)}	-	-	-	-

Further specifications:

- For t_I and t_{II} made of S275, S320GD, S350GD, HX340LAD or HX380LAD with $R_{m,min} \geq 390 \text{ N/mm}^2$, the values marked with ^{a)} may be increased by 8.3%.

Fasteners for connection of steel structural members in steel and high bay warehouse structures

TDBL-T-10.6 x L
 TDBLF-T-10.6 x L

Annex 25

Ansicht = view

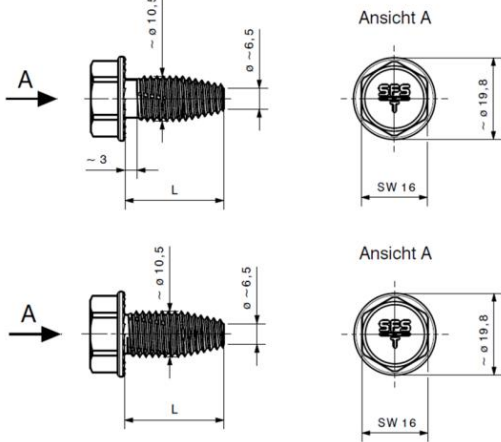

Materials

Screw: Carbon steel
 tempered and coated

Component I: S355 – EN 10025-2
 S390GD through S450GD – EN 10346
 HX420LAD through HX460LAD – EN 10346

Component II: S355 – EN 10025-2
 S390GD through S450GD – EN 10346
 HX420LAD through HX460LAD – EN 10346

pre-drilling diameter

Component I: $d_{pd,I} = 12.0 \text{ mm}$
 Component II: $d_{pd,II}$ see table

		$t_{II} \text{ [mm]}$									
		3.00	4.00	5.00	6.00	8.00	10.00	12.00	14.00	15.00	
		$d_{pd,II} = 10.0 \text{ mm}$									
$V_{R,k} \text{ [kN]}$	5.00	14.85	24.06	26.04	26.04	26.04	26.04	26.04	26.04	26.04	
	6.00	14.85	24.06	26.04	29.61	29.61	29.61	29.61	29.61	-	
	8.00	14.85	24.06	26.04	29.61	31.09	31.09	31.09	-	-	
	$t_i \text{ [mm]}$	10.00	14.85	24.06	26.04	29.61	31.09	31.09	-	-	-
	12.00	14.85	24.06	26.04	29.61	31.09	-	-	-	-	
$N_{R,k} \text{ [kN]}$	5.00	9.21	15.03	19.98	28.47	29.03	29.03	29.03	29.03	29.03	
	6.00	9.21	15.03	19.98	28.47	36.71	36.71	36.71	36.71	-	
	8.00	9.21	15.03	19.98	28.47	37.80	40.55	40.55	-	-	
	$t_i \text{ [mm]}$	10.00	9.21	15.03	19.98	28.47	37.80	40.55	-	-	-
	12.00	9.21	15.03	19.98	28.47	37.80	-	-	-	-	

No further specifications.

Fasteners for connection of steel structural members in steel and high bay warehouse structures

TDBL-T-10.6 x L
 TDBLF-T-10.6 x L

Annex 26

Ansicht = view

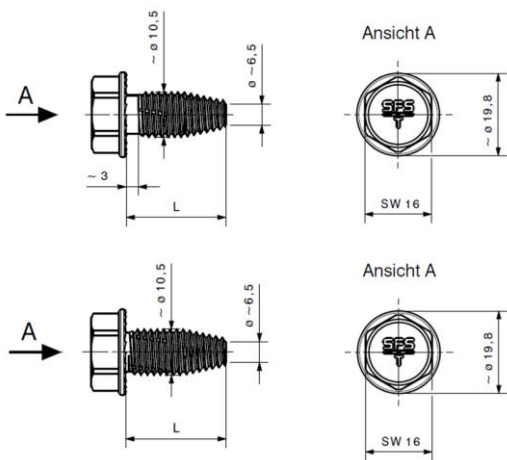

Materials

Screw: Carbon steel
tempered and coated

Component I: S235 through S275 – EN 10025-2
S280GD through S350GD – EN 10346
HX300LAD through HX380LAD – EN 10346

Component II: S235 through S275 – EN 10025-2
S280GD through S350GD – EN 10346
HX300LAD through HX380LAD – EN 10346

pre-drilling diameter

Component I: $d_{pd,I} = 10.0 \text{ mm}$
Component II: $d_{pd,II}$ see table

		$t_{II} \text{ [mm]}$			
		3.00	4.00	5.00	≥ 6.00
		$d_{pd,II} = 10.0 \text{ mm}$			
$V_{R,k} \text{ [kN]}$	$t_i \text{ [mm]}$	2 x 0.88	2 x 0.90	2 x 1.00	2 x 1.13
		10.30	10.39	10.83	11.56
		12.28	13.47	14.09	14.70
		17.73	17.73	17.73	17.73
		7.21	7.81	7.81	7.81
		7.21	7.85	7.85	7.85
		7.21	8.04	8.04	8.04
		7.21	10.06	10.06	10.06
$N_{R,k} \text{ [kN]}$	$t_i \text{ [mm]}$	2 x 1.25	2 x 1.50	2 x 1.75	2 x 2.00
		12.28	13.47	14.09	14.70
		17.73	17.73	17.73	17.73
		7.21	7.81	7.81	7.81
		7.21	7.85	7.85	7.85
		7.21	8.04	8.04	8.04
		7.21	10.06	10.06	10.06
		7.21	11.76	12.08	12.08
	7.21	11.76	15.64	17.36	
	7.21	11.76	15.64	19.98	
	7.21	11.76	15.64	22.28	

Further specifications:

- For t_i and t_{II} made of S275, S320GD, S350GD, HX340LAD or HX380LAD with $R_{m,min} \geq 390 \text{ N/mm}^2$, the values may be increased by 8.3%.

Fasteners for connection of steel structural members in steel and high bay warehouse structures

TDBL-T-10.6 x L
TDBLF-T-10.6 x L

Annex 27

<p style="text-align: center;">Ansicht = view</p>	<p>Materials</p> <p>Screw: Carbon steel tempered and coated</p> <p>Component I: S355 – EN 10025-2 S390GD through S450GD – EN 10346 HX420LAD through HX460LAD – EN 10346</p> <p>Component II: S355 – EN 10025-2 S390GD through S450GD – EN 10346 HX420LAD through HX460LAD – EN 10346</p> <hr/> <p><u>pre-drilling diameter</u></p> <p>Component I: $d_{pd,I} = 10.0 \text{ mm}$ Component II: $d_{pd,II}$ see table</p>
---	---

		$t_{II} \text{ [mm]}$				
		3.00	4.00	5.00	≥ 6.00	
		$d_{pd,II} = 10.0 \text{ mm}$				
$V_{R,k} \text{ [kN]}$	$t_i \text{ [mm]}$	2 x 0.88	13.16	13.16	13.16	13.16
		2 x 0.90	13.28	13.28	13.28	13.28
		2 x 1.00	13.84	13.84	13.84	13.84
		2 x 1.13	14.77	14.77	14.77	14.77
		2 x 1.25	15.69	15.69	15.69	15.69
		2 x 1.50	17.21	17.21	17.21	17.21
		2 x 1.75	18.00	18.00	18.00	18.00
		2 x 2.00	18.78	22.66	18.78	22.66
$N_{R,k} \text{ [kN]}$	$t_i \text{ [mm]}$	2 x 0.88	9.21	9.21	9.21	9.21
		2 x 0.90	9.21	9.21	9.21	9.21
		2 x 1.00	9.21	9.21	9.21	9.21
		2 x 1.13	9.21	10.90	10.90	10.90
		2 x 1.25	9.21	15.03	15.03	15.03
		2 x 1.50	9.21	15.03	19.98	19.98
		2 x 1.75	9.21	15.03	19.98	21.65
		2 x 2.00	9.21	15.03	19.98	28.47

No further specifications.

Fasteners for connection of steel structural members in steel and high bay warehouse structures

TDBL-T-10.6 x L
TDBLF-T-10.6 x L

Annex 28

<p style="text-align: center;">Ansicht = view</p>	<p>Materials</p> <p>Screw: Carbon steel tempered and coated</p> <p>Component I: S235 through S355 – EN 10025-2 S280GD through S450GD – EN 10346 HX300LAD through HX460LAD – EN 10346</p> <p>Component II: S235 through S355 – EN 10025-2 S280GD through S450GD – EN 10346 HX300LAD through HX460LAD – EN 10346</p> <p>pre-drilling diameter</p> <p>Component I: $d_{pd,I} = 8.5 \times 28.5 \text{ mm}$ (slotted hole) Component II: $d_{pd,II}$ see table</p>
---	---

		$t_{II} \text{ [mm]}$		
		3.00	≥ 4.00	
		$d_{pd,II} = 10.0 \text{ mm}$		
$V_{R,k} \text{ [kN]}$	2×0.88	6.28 ^{a)}	6.28 ^{a)}	
	2×0.90	6.85 ^{a)}	6.85 ^{a)}	
	2×1.00	9.68 ^{a)}	9.68 ^{a)}	
	2×1.13	9.70 ^{a)}	9.70 ^{a)}	
	$t_I \text{ [mm]}$	2×1.25	9.71 ^{a)}	9.71 ^{a)}
		2×1.50	10.74 ^{b)}	10.74 ^{b)}
		2×1.75	12.32 ^{b)}	12.32 ^{b)}
		2×2.00	13.89 ^{b)}	13.89 ^{b)}
$N_{R,k} \text{ [kN]}$	2×0.88	4.26 ^{a)}	4.26 ^{a)}	
	2×0.90	4.32 ^{a)}	4.32 ^{a)}	
	2×1.00	4.63 ^{a)}	4.63 ^{a)}	
	2×1.13	6.03 ^{a)}	6.03 ^{a)}	
	$t_I \text{ [mm]}$	2×1.25	7.21 ^{b)}	7.42 ^{a)}
		2×1.50	7.21 ^{b)}	7.86 ^{a)}
		2×1.75	7.21 ^{b)}	8.68 ^{a)}
		2×2.00	7.21 ^{b)}	9.50 ^{a)}

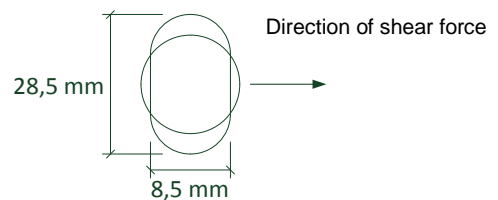

Further specifications:

- For t_I and t_{II} made of S275, S320GD, S350GD, HX340LAD or HX380LAD with $R_{m,min} \geq 390 \text{ N/mm}^2$, the values may be increased by 8.3%.
- For t_I and t_{II} made of S355, S390GD, S420GD, S450GD, HX420LAD or HX460LAD with $R_{m,min} \geq 460 \text{ N/mm}^2$ the values marked with ^{a)} may be increased by 8.3% and the values marked with ^{b)} may be increased by 27.8%.

Fasteners for connection of steel structural members in steel and high bay warehouse structures

TDBL-T-10.6 x L
 TDBLF-T-10.6 x L

Ansicht = view

Materials

Screw: Carbon steel
tempered and coated

Component I: S235 through S275 – EN 10025-2
S280GD through S350GD – EN 10346
HX300LAD through HX380LAD – EN 10346

Component II: S235 through S275 – EN 10025-2
S280GD through S350GD – EN 10346
HX300LAD through HX380LAD – EN 10346

pre-drilling diameter

Component I: $d_{pd,I} = 8.5 \times 28.5 \text{ mm}$ (slotted hole)
 Component II: $d_{pd,II}$ see table

		$t_{II} \text{ [mm]}$										
		1.00	1.13	1.25	1.50	1.75	2.00	3.00	4.00	6.00	≥ 8.00	
		$d_{pd,II} = 9.0 \text{ mm}$					$d_{pd,II} = 10.0 \text{ mm}$					
$V_{R,k} \text{ [kN]}$	0.88	1.98	1.98	1.98	1.98	1.98	1.98	1.98	1.98	1.98	1.98	
	0.90	2.02	2.02	2.02	2.02	2.02	2.02	2.02	2.02	2.02	2.02	
	1.00	2.20	2.20	2.20	2.20	2.20	2.20	2.20	2.20	2.20	2.20	
	1.13	2.20	2.95	2.95	2.95	2.95	2.95	2.95	2.95	2.95	2.95	
	1.25	2.20	2.95	3.64	3.64	3.64	3.64	3.64	3.64	3.64	3.64	
	$t_I \text{ [mm]}$	1.50	2.20	2.95	3.64	5.07	5.07	5.07	5.07	5.07	5.07	5.07
		1.75	2.20	2.95	3.64	5.07	7.09	7.09	7.09	7.09	7.09	7.09
		2.00	2.20	2.95	3.64	5.07	7.09	9.10	9.10	9.10	9.10	9.10
		3.00	2.20	2.95	3.64	5.07	7.09	9.10	13.53	13.53	13.53	13.53
	4.00	2.20	2.95	3.64	5.07	7.09	9.10	13.53	15.40	15.40	15.40	
$N_{R,k} \text{ [kN]}$	0.88	1.66	1.66	1.66	1.66	1.66	1.66	1.66	1.66	1.66	1.66	
	0.90	1.74	1.74	1.74	1.74	1.74	1.74	1.74	1.74	1.74	1.74	
	1.00	1.75	2.12	2.12	2.12	2.12	2.12	2.12	2.12	2.12	2.12	
	1.13	1.75	2.16	2.57	2.72	2.72	2.72	2.72	2.72	2.72	2.72	
	1.25	1.75	2.16	2.57	3.28	3.28	3.28	3.28	3.28	3.28	3.28	
	$t_I \text{ [mm]}$	1.50	1.75	2.16	2.57	3.44	4.43	4.43	4.43	4.43	4.43	4.43
		1.75	1.75	2.16	2.57	3.44	4.46	5.48	5.58	5.58	5.58	5.58
		2.00	1.75	2.16	2.57	3.44	4.46	5.48	6.72	6.72	6.72	6.72
		3.00	1.75	2.16	2.57	3.44	4.46	5.48	7.21	9.27	9.27	9.27
	4.00	1.75	2.16	2.57	3.44	4.46	5.48	7.21	11.72	11.72	11.72	

Further specifications:
 - For t_I and t_{II} made of S275, S320GD, S350GD, HX340LAD or HX380LAD with $R_{m,min} \geq 390 \text{ N/mm}^2$, the values may be increased by 8.3%.

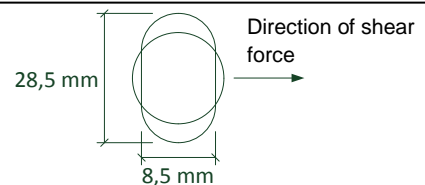

<p style="text-align: center;">Ansicht = view</p>	<p>Materials</p> <p>Screw: Carbon steel tempered and coated</p> <p>Component I: S355 – EN 10025-2 S390GD through S450GD – EN 10346 HX420LAD through HX460LAD – EN 10346</p> <p>Component II: S355 – EN 10025-2 S390GD through S450GD – EN 10346 HX420LAD through HX460LAD – EN 10346</p> <hr/> <p><u>pre-drilling diameter</u></p> <p>Component I: $d_{pd,I} = 8.5 \times 28.5 \text{ mm}$ (slotted hole) Component II: $d_{pd,II}$ see table</p>
---	--

		$t_{II} \text{ [mm]}$										
		1.00	1.13	1.25	1.50	1.75	2.00	3.00	4.00	6.00	≥ 8.00	
		$d_{pd,II} = 9.0 \text{ mm}$						$d_{pd,II} = 10.0 \text{ mm}$				
$V_{R,k}$ [kN]	t_I [mm]	0.88	2.15	2.15	2.15	2.15	2.15	2.15	2.15	2.15	2.15	2.15
		0.90	2.19	2.19	2.19	2.19	2.19	2.19	2.19	2.19	2.19	2.19
		1.00	2.38	2.38	2.38	2.38	2.38	2.38	2.38	2.38	2.38	2.38
		1.13	2.38	3.20	3.20	3.20	3.20	3.20	3.20	3.20	3.20	3.20
		1.25	2.38	3.20	3.94	3.94	3.94	3.94	3.94	3.94	3.94	3.94
		1.50	2.38	3.20	3.94	5.49	5.49	5.49	5.49	5.49	5.49	5.49
		1.75	2.38	3.20	3.94	5.49	7.68	7.68	7.68	7.68	7.68	7.68
		2.00	2.38	3.20	3.94	5.49	7.68	9.86	9.86	9.86	9.86	9.86
		3.00	2.38	3.20	3.94	5.49	7.68	9.86	17.29	17.29	17.29	17.29
	4.00	2.38	3.20	3.94	5.49	7.68	9.86	17.29	19.68	19.68	19.68	
$N_{R,k}$ [kN]	t_I [mm]	0.88	1.80	1.80	1.80	1.80	1.80	1.80	1.80	1.80	1.80	1.80
		0.90	1.89	1.89	1.89	1.89	1.89	1.89	1.89	1.89	1.89	1.89
		1.00	1.90	2.30	2.30	2.30	2.30	2.30	2.30	2.30	2.30	2.30
		1.13	1.90	2.34	2.78	2.95	2.95	2.95	2.95	2.95	2.95	2.95
		1.25	1.90	2.34	2.78	3.55	3.55	3.55	3.55	3.55	3.55	3.55
		1.50	1.90	2.34	2.78	3.73	4.80	4.80	4.80	4.80	4.80	4.80
		1.75	1.90	2.34	2.78	3.73	4.83	5.94	6.05	6.05	6.05	6.05
		2.00	1.90	2.34	2.78	3.73	4.83	5.94	7.28	7.28	7.28	7.28
		3.00	1.90	2.34	2.78	3.73	4.83	5.94	9.21	11.85	11.85	11.85
	4.00	1.90	2.34	2.78	3.73	4.83	5.94	9.21	14.98	14.98	14.98	

No further specifications.

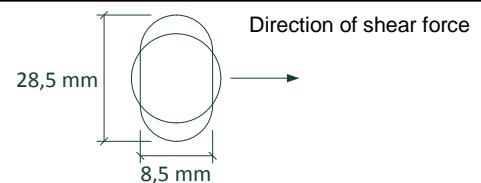

Fasteners for connection of steel structural members in steel and high bay warehouse structures

TDBL-T-10.6 x L
TDBLF-T-10.6 x L

Annex 31

<p style="text-align: center;">Ansicht = view</p>	<p>Materials</p> <p>Screw: Carbon steel tempered and coated</p> <p>Component I: S235 – EN 10025-2 S280GD through S320GD – EN 10346 HX300LAD – EN 10346</p> <p>Component II: S235 – EN 10025-2 S280GD through S320GD – EN 10346 HX300LAD – EN 10346</p> <hr/> <p><u>pre-drilling diameter</u></p> <p>Component I: $d_{pd,I} = d_{pd,II}$ Component II: see table</p>
---	--

		t_{II} [mm]																	
		1.00	1.25	1.50	2.00	3.00	4.00	5.00	6.00	8.00	≥ 10.00								
		$d_{pd,I} = d_{pd,II} = 9.0$ mm					$d_{pd,I} = d_{pd,II} = 10.0$ mm												
$V_{R,k}$ [kN]	t_I [mm]	1.00	1.13	1.25	1.50	1.75	2.00	3.00	4.00	2.22	2.39	2.55	4.02	4.29	5.71	7.13	9.96	11.3	14.4
	1.00	1.13	1.25	1.50	1.75	2.00	3.00	4.00	2.22	2.39	2.55	4.02	4.29	5.71	7.13	9.96	11.3	14.4	
	1.13	1.25	1.50	1.75	2.00	3.00	4.00	2.39	2.55	4.02	4.29	5.71	7.13	9.96	11.3	14.4			
	1.25	1.50	1.75	2.00	3.00	4.00	2.55	4.02	4.29	5.71	7.13	9.96	11.3	14.4					
	1.50	1.75	2.00	3.00	4.00	4.02	4.29	5.71	7.13	9.96	11.3	14.4							
	1.75	2.00	3.00	4.00	4.29	5.71	7.13	9.96	11.3	14.4									
	2.00	3.00	4.00	5.71	7.13	9.96	11.3	14.4											
	3.00	4.00	7.13	9.96	11.3	14.4													
$N_{R,k}$ [kN]	t_I [mm]	1.00	1.13	1.25	1.50	1.75	2.00	3.00	4.00	2.22	2.39	2.55	4.02	4.29	5.71	7.13	9.96	11.3	14.4
	1.00	1.13	1.25	1.50	1.75	2.00	3.00	4.00	2.22	2.39	2.55	4.02	4.29	5.71	7.13	9.96	11.3	14.4	
	1.13	1.25	1.50	1.75	2.00	3.00	4.00	2.39	2.55	4.02	4.29	5.71	7.13	9.96	11.3	14.4			
	1.25	1.50	1.75	2.00	3.00	4.00	2.55	4.02	4.29	5.71	7.13	9.96	11.3	14.4					
	1.50	1.75	2.00	3.00	4.00	4.02	4.29	5.71	7.13	9.96	11.3	14.4							
	1.75	2.00	3.00	4.00	4.29	5.71	7.13	9.96	11.3	14.4									
	2.00	3.00	4.00	5.71	7.13	9.96	11.3	14.4											
	3.00	4.00	7.13	9.96	11.3	14.4													

No further specifications.

Fasteners for connection of steel structural members in steel and high bay warehouse structures

TDBL-T-10.6 x L
 TDBLF-T-10.6 x L

Annex 32

<p style="text-align: center;">Ansicht = view</p>	<p>Materials</p> <p>Screw: Carbon steel tempered and coated</p> <p>Component I: S275 through S355 – EN 10025-2 S350GD through S450GD – EN 10346 HX340LAD through HX460LAD – EN 10346</p> <p>Component II: S275 through S355 – EN 10025-2 S350GD through S450GD – EN 10346 HX340LAD through HX460LAD – EN 10346</p> <p><u>pre-drilling diameter</u></p> <p>Component I: $d_{pd,I} = d_{pd,II}$ Component II: see table</p>
---	--

		t_{II} [mm]															
		1.00	1.25	1.50	2.00	3.00	4.00	5.00	6.00	8.00	≥ 10.00						
		$d_{pd,I} = d_{pd,II} = 9.0$ mm					$d_{pd,I} = d_{pd,II} = 10.0$ mm										
$V_{R,k}$ [kN]	t_I [mm]	1.00	1.13	1.25	1.50	1.75	2.00	3.00	4.00	1.00	1.13	1.25	1.50	1.75	2.00	3.00	4.00
	1.00	3.24 -	3.90 -	4.56 -	5.88 -	5.88 ac	5.88 ac	5.88 ac	5.88 ac	5.88 ac	5.88 ac	5.88 ac	5.88 ac	5.88 ac	5.88 ac	5.88 ac	
	1.13	-	4.44 -	5.06 -	6.30 -	7.54 -	7.54 ac	7.54 ac	7.54 ac	7.54 ac	7.54 ac	7.54 ac	7.54 ac	7.54 ac	7.54 ac	7.54 ac	
	1.25	-	5.03 -	5.41 -	7.68 -	9.19 -	9.19 ac	9.19 ac	9.19 ac	9.19 ac	9.19 ac	9.19 ac	9.19 ac	9.19 ac	9.19 ac	9.19 ac	
	1.50	-	-	6.81 -	7.95 -	10.2 -	12.5 ac	12.5 ac	12.5 ac	12.5 ac	12.5 ac	12.5 ac	12.5 ac	12.5 ac	12.5 ac	12.5 ac	
	1.75	-	-	-	8.82 -	10.4 -	12.5 ac	12.5 ac	13.7 ac	13.7 ac	13.7 ac	13.7 ac	13.7 ac	13.7 ac	13.7 ac	13.7 ac	
	2.00	-	-	-	10.0 -	11.2 -	12.5 ac	12.5 ac	14.8 ac	14.8 ac	14.8 ac	14.8 ac	14.8 ac	14.8 ac	14.8 ac	14.8 ac	
	3.00	-	-	-	-	13.8 -	15.6 ac	15.6 ac	19.2 ac	22.8 ac	22.8 ac	22.8 ac	22.8 ac	22.8 ac	22.8 ac	22.8 ac	
4.00	-	-	-	-	-	25.0 ac	25.0 ac	25.0 ac	25.0 ac	25.0 ac	25.0 ac	25.0 ac	25.0 ac	25.0 ac	25.0 ac		
$N_{R,k}$ [kN]	t_I [mm]	1.00	1.13	1.25	1.50	1.75	2.00	3.00	4.00	1.00	1.13	1.25	1.50	1.75	2.00	3.00	4.00
	1.00	2.43 -	2.53 -	2.62 -	4.58 -	4.69 -	4.69 ac	4.69 ac	4.69 ac	4.69 ac	4.69 ac	4.69 ac	4.69 ac	4.69 ac	4.69 ac	4.69 ac	
	1.13	-	2.53 -	2.62 -	4.58 -	6.07 -	6.07 ac	6.07 ac	6.07 ac	6.07 ac	6.07 ac	6.07 ac	6.07 ac	6.07 ac	6.07 ac	6.07 ac	
	1.25	-	2.53 -	2.62 -	4.58 -	7.45 -	7.45 ac	7.45 ac	7.45 ac	7.45 ac	7.45 ac	7.45 ac	7.45 ac	7.45 ac	7.45 ac	7.45 ac	
	1.50	-	-	2.62 -	4.58 -	8.70 -	10.2 ac	10.2 ac	10.2 ac	10.2 ac	10.2 ac	10.2 ac	10.2 ac	10.2 ac	10.2 ac	10.2 ac	
	1.75	-	-	-	4.58 -	8.70 -	12.0 ac	12.3 ac	12.3 ac	12.3 ac	12.3 ac	12.3 ac	12.3 ac	12.3 ac	12.3 ac	12.3 ac	
	2.00	-	-	-	4.58 -	8.70 -	12.0 -	14.4 -	14.4 ac	14.4 ac	14.4 ac	14.4 ac	14.4 ac	14.4 ac	14.4 ac	14.4 ac	
	3.00	-	-	-	-	8.70 -	12.0 -	14.4 -	14.4 -	14.4 ac	14.4 ac	14.4 ac	14.4 ac	14.4 ac	14.4 ac	14.4 ac	
4.00	-	-	-	-	-	12.0 -	14.4 -	14.4 -	14.4 ac	14.4 ac	14.4 ac	14.4 ac	14.4 ac	14.4 ac	14.4 ac		

No further specifications.

Fasteners for connection of steel structural members in steel and high bay warehouse structures

TDBL-T-10.6 x L
TDBLF-T-10.6 x L

Annex 33

<p style="text-align: center;">Ansicht = view</p>	<p>Materials</p> <p>Screw: Carbon steel tempered and coated</p> <p>Component I: S235 – EN 10025-2 S280GD through S320GD – EN 10346 HX300LAD – EN 10346</p> <p>Component II: S235 – EN 10025-2 S280GD through S320GD – EN 10346 HX300LAD – EN 10346</p> <hr/> <p><u>pre-drilling diameter</u></p> <p>Component I: slotted hole 8.0 mm x 20.0 mm Component II: slotted hole 8.0 mm x 20.0 mm</p>
---	---

		t_{II} [mm]			
		1.00	1.50	2.00	3.00
		$d_{pd.I} = d_{pd.II} = 8.0 \text{ mm} \times 20.0 \text{ mm}$			
$V_{R.k}$ [kN]	1.00	1.41 -	1.41 -	1.41 -	1.41 -
	1.50	- -	2.75 -	2.75 -	2.75 -
t_I [mm]	2.00	- -	-	4.01 -	4.01 -
	3.00	- -	- -	- -	10.2 -
$N_{R.k}$ [kN]	1.00	- -	- -	- -	- -
	1.50	- -	- -	- -	- -
t_I [mm]	2.00	- -	- -	- -	- -
	3.00	- -	- -	- -	- -

Further specifications:

Fasteners for connection of steel structural members in steel and high bay warehouse structures	Annex 34
TDBL-T-10.6 x L TDBLF-T-10.6 x L	

<p style="text-align: center;">Ansicht = view</p>	<p>Materials</p> <p>Screw: Carbon steel tempered and coated</p> <p>Component I: S275 through S355 – EN 10025-2 S350GD through S450GD – EN 10346 HX340LAD through HX460LAD – EN 10346</p> <p>Component II: S275 through S355 – EN 10025-2 S350GD through S450GD – EN 10346 HX340LAD through HX460LAD – EN 10346</p> <hr/> <p><u>pre-drilling diameter</u></p> <p>Component I: slotted hole 8.0 mm x 20.0 mm Component II: slotted hole 8.0 mm x 20.0 mm</p>
---	---

		t_{II} [mm]			
		1.00	1.50	2.00	3.00
		$d_{pd.I} = d_{pd.II} = 8.0 \text{ mm} \times 20.0 \text{ mm}$			
V_{R.k} [kN]	1.00	1.61 -	1.61 -	1.61 -	1.61 -
	1.50	- -	3.13 -	3.13 -	3.13 -
t_I [mm]	2.00	- -	-	4.57 -	4.57 -
	3.00	- -	- -	- -	11.9 -
N_{R.k} [kN]	1.00	- -	- -	- -	- -
	1.50	- -	- -	- -	- -
t_I [mm]	2.00	- -	- -	- -	- -
	3.00	- -	- -	- -	- -

Further specifications:

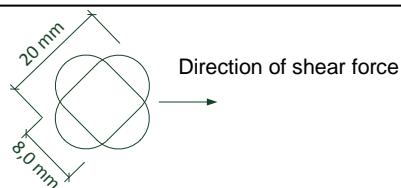

Fasteners for connection of steel structural members in steel and high bay warehouse structures

TDBL-T-10.6 x L
TDBLF-T-10.6 x L

Annex 35

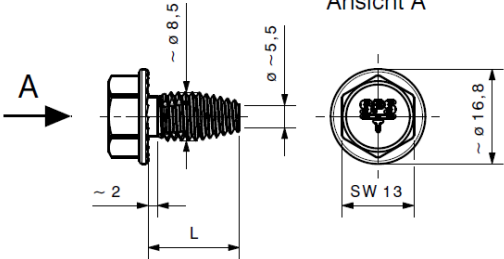
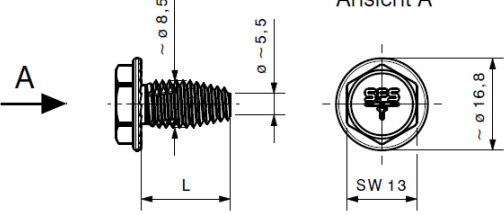
<p style="text-align: center;">Ansicht = view</p> <p style="text-align: center;">Ansicht A</p>  <p style="text-align: center;">Ansicht A</p> 	<p><u>Materials</u></p> <p>Screw: Carbon steel tempered and coated</p> <p>Component I: S235 – EN 10025-2 S280GD through S320GD – EN 10346 HX300LAD – EN 10346</p> <p>Component II: S235 – EN 10025-2 S280GD through S320GD – EN 10346 HX300LAD – EN 10346</p> <p><u>pre-drilling diameter</u></p> <p>Component I: $d_{pd,I} = d_{pd,II}$ Component II: see table</p>
---	---

		t_{II} [mm]											
		0.88	0.90	1.00	1.25	1.50	2.00	3.00	4.00	6.00	8.00	≥ 6.00	
		$d_{pd,I} = d_{pd,II} = 7.5$ mm						$d_{pd,I} = d_{pd,II} = 8.0$ mm					
$V_{R,k}$ [kN]	0.88	2.37 -	2.40 -	2.56 -	2.94 -	3.33 -	4.11 ac	4.11 ac	4.11 ac	4.11 ac	4.11 ac	4.11 ac	
	0.90	- -	2.62 -	2.62 -	3.04 -	3.47 -	4.31 -	4.95 ac	4.95 ac	4.95 ac	4.95 ac	4.95 ac	
	1.00	- -	- -	2.84 -	3.36 -	3.89 -	4.93 -	7.02 ac	7.02 ac	7.02 ac	7.02 ac	7.02 ac	
	1.13	- -	- -	- -	3.77 -	4.32 -	4.93 -	7.62 -	8.73 ac	8.73 ac	8.73 ac	8.73 ac	
	1.25	- -	- -	- -	4.14 -	4.71 -	5.86 -	8.14 -	10.4 ac	10.4 ac	10.4 ac	10.4 ac	
	t_I [mm]	1.50	- -	- -	- -	- -	5.52 -	6.15 -	8.14 -	10.4 -	11.2 ac	11.2 ac	11.2 ac
		1.75	- -	- -	- -	- -	- -	8.00 -	8.96 -	10.4 -	11.9 ac	12.8 ac	12.8 ac
		2.00	- -	- -	- -	- -	- -	9.99 -	10.7 -	11.5 -	13.0 -	14.5 ac	14.5 ac
3.00		- -	- -	- -	- -	- -	- -	14.0 -	15.5 -	18.5 -	21.6 -	24.6 ac	
4.00	- -	- -	- -	- -	- -	- -	- -	- -	- -	- -	- -		
$N_{R,k}$ [kN]	0.88	1.10 -	1.13 -	1.29 -	1.84 -	2.59 -	3.11 ac	3.11 ac	3.11 ac	3.11 ac	3.11 ac	3.11 ac	
	0.90	- -	1.13 -	1.29 -	1.84 -	2.59 -	3.17 -	3.17 ac	3.17 ac	3.17 ac	3.17 ac	3.17 ac	
	1.00	- -	- -	1.29 -	1.84 -	2.59 -	3.47 -	3.47 ac	3.47 ac	3.47 ac	3.47 ac	3.47 ac	
	1.13	- -	- -	- -	1.84 -	2.59 -	3.88 -	4.29 -	4.29 ac	4.29 ac	4.29 ac	4.29 ac	
	1.25	- -	- -	- -	1.84 -	2.59 -	3.88 -	5.11 -	5.11 ac	5.11 ac	5.11 ac	5.11 ac	
	t_I [mm]	1.50	- -	- -	- -	- -	2.59 -	3.88 -	7.86 -	9.06 -	9.06 ac	9.06 ac	9.06 ac
		1.75	- -	- -	- -	- -	- -	3.88 -	7.86 -	10.1 -	10.1 ac	10.1 ac	10.1 ac
		2.00	- -	- -	- -	- -	- -	3.88 -	7.86 -	11.1 -	11.1 -	11.1 ac	11.1 ac
3.00		- -	- -	- -	- -	- -	- -	7.86 -	11.1 -	11.1 -	11.1 -	11.1 ac	
4.00	- -	- -	- -	- -	- -	- -	- -	- -	- -	- -	- -		

No further specifications.

Fasteners for connection of steel structural members in steel and high bay warehouse structures

TDBL-T-8.6 x L
TDBLF-T-F-8.6 x L

Annex 36

<p style="text-align: center;">Ansicht = view</p> <p style="text-align: center;">Ansicht A</p>	<p><u>Materials</u></p> <p>Screw: Carbon steel tempered and coated</p> <p>Component I: S275 through S355 – EN 10025-2 S350GD through S450GD – EN 10346 HX340LAD through HX460LAD – EN 10346</p> <p>Component II: S275 through S355 – EN 10025-2 S350GD through S450GD – EN 10346 HX340LAD through HX460LAD – EN 10346</p> <p><u>pre-drilling diameter</u></p> <p>Component I: $d_{pd,I} = d_{pd,II}$ Component II: see table</p>
--	---

		t_{II} [mm]										
		0.88	0.90	1.00	1.25	1.50	2.00	3.00	4.00	6.00	8.00	≥ 6.00
		$d_{pd,I} = d_{pd,II} = 7.5$ mm						$d_{pd,I} = d_{pd,II} = 8.0$ mm				
$V_{R,k}$ [kN]	t_I [mm]	0.88	0.90	1.00	1.25	1.50	2.00	3.00	4.00	6.00	8.00	≥ 6.00
	0.88	2.38 -	2.41 -	2.57 -	2.96 -	3.35 -	4.14 ac	4.14 ac	4.14 ac	4.14 ac	4.14 ac	4.14 ac
	0.90	- -	2.50 -	2.68 -	3.12 -	3.56 -	4.44 -	4.73 ac	4.73 ac	4.73 ac	4.73 ac	4.73 ac
	1.00	- -	- -	3.11 -	3.68 -	4.25 -	5.40 -	4.68 ac	7.68 ac	7.68 ac	7.68 ac	7.68 ac
	1.13	- -	- -	- -	4.17 -	4.73 -	5.85 -	8.08 -	9.19 ac	9.19 ac	9.19 ac	9.19 ac
	1.25	- -	- -	- -	4.68 -	5.23 -	6.32 -	8.51 -	10.7 ac	10.7 ac	10.7 ac	10.7 ac
	1.50	- -	- -	- -	- -	6.14 -	6.87 -	8.51 -	10.7 -	10.7 ac	12.8 ac	12.8 ac
	1.75	- -	- -	- -	- -	- -	8.33 -	9.38 -	10.7 -	10.7 ac	12.8 ac	13.6 ac
2.00	- -	- -	- -	- -	- -	9.99 -	10.7 -	11.5 -	11.5 -	13.0 ac	14.5 ac	
3.00	- -	- -	- -	- -	- -	- -	14.0 -	15.5 -	15.5 -	18.5 -	24.6 ac	
4.00	- -	- -	- -	- -	- -	- -	- -	- -	- -	- -	- -	
$N_{R,k}$ [kN]	t_I [mm]	0.88	0.90	1.00	1.25	1.50	2.00	3.00	4.00	6.00	8.00	≥ 6.00
	0.88	1.11 -	1.16 -	1.42 -	1.88 -	2.66 -	3.12 ac	3.12 ac	3.12 ac	3.12 ac	3.12 ac	3.12 ac
	0.90	- -	1.16 -	1.42 -	1.88 -	2.66 -	3.23 -	3.23 ac	3.23 ac	3.23 ac	3.23 ac	3.23 ac
	1.00	- -	- -	1.42 -	1.88 -	2.66 -	3.80 -	3.80 ac	3.80 ac	3.80 ac	3.80 ac	3.80 ac
	1.13	- -	- -	- -	1.88 -	2.66 -	4.42 -	4.52 -	4.52 ac	4.52 ac	4.52 ac	4.52 ac
	1.25	- -	- -	- -	1.88 -	2.66 -	4.42 -	5.23 -	5.23 ac	5.23 ac	5.23 ac	5.23 ac
	1.50	- -	- -	- -	- -	2.66 -	4.42 -	8.96 -	9.29 -	9.29 ac	9.29 ac	9.29 ac
	1.75	- -	- -	- -	- -	- -	4.42 -	8.96 -	10.2 -	10.2 ac	10.2 ac	10.2 ac
2.00	- -	- -	- -	- -	- -	4.42 -	8.96 -	11.1 -	11.1 -	11.1 ac	11.1 ac	
3.00	- -	- -	- -	- -	- -	- -	8.96 -	11.1 -	11.1 -	11.1 -	11.1 ac	
4.00	- -	- -	- -	- -	- -	- -	- -	- -	- -	- -	- -	

No further specifications.

Fasteners for connection of steel structural members in steel and high bay warehouse structures

TDBL-T-8.6 x L
TDBLF-T-F-8.6 x L

Annex 37

Ansicht = view

Ansicht A

Ansicht A

Materials

Screw: Carbon steel
tempered and coated

Component I: S275 through S355 – EN 10025-2
S350GD through S450GD – EN 10346
HX340LAD through HX460LAD – EN 10346

Component II: S275 through S355 – EN 10025-2
S350GD through S450GD – EN 10346
HX340LAD through HX460LAD – EN 10346

pre-drilling diameter

Component I: $d_{pd,I} = d_{pd,II}$
Component II: see table

		t_{II} [mm]									
		0.88	0.90	1.00	1.25	1.50	2.00	3.00	4.00	≥ 6.00	
									$d_{pd,I} = d_{pd,II} = 8.0$ mm		
$V_{R,k}$ [kN]	t_I [mm]	2 x 0.88	- -	- -	- -	- -	- -	- -	6.90 ac	6.90 ac	6.90 ac
		2 x 0.90	- -	- -	- -	- -	- -	- -	7.43 ac	7.43 ac	7.43 ac
		2 x 1.00	- -	- -	- -	- -	- -	- -	10.1 ac	10.1 ac	10.1 ac
		2 x 1.13	- -	- -	- -	- -	- -	- -	10.1 -	14.5 ac	14.5 ac
		2 x 1.25	- -	- -	- -	- -	- -	- -	13.9 -	18.9 ac	18.9 ac
		2 x 1.50	- -	- -	- -	- -	- -	- -	13.9 -	18.9 ac	22.7 ac
		2 x 1.75	- -	- -	- -	- -	- -	- -	13.9 -	18.9 ac	22.7 ac
		2 x 2.00	- -	- -	- -	- -	- -	- -	13.9 -	18.9 ac	22.7 ac
$N_{R,k}$ [kN]	t_I [mm]	2 x 0.88	- -	- -	- -	- -	- -	- -	3.11 ac	3.11 ac	3.11 ac
		2 x 0.90	- -	- -	- -	- -	- -	- -	3.17 ac	3.17 ac	3.17 ac
		2 x 1.00	- -	- -	- -	- -	- -	- -	3.47 ac	3.47 ac	3.47 ac
		2 x 1.13	- -	- -	- -	- -	- -	- -	4.29 -	4.29 ac	4.29 ac
		2 x 1.25	- -	- -	- -	- -	- -	- -	5.11 -	5.11 ac	5.11 ac
		2 x 1.50	- -	- -	- -	- -	- -	- -	7.88 -	9.08 ac	9.08 ac
		2 x 1.75	- -	- -	- -	- -	- -	- -	7.88 -	10.1 ac	10.1 ac
		2 x 2.00	- -	- -	- -	- -	- -	- -	7.88 -	11.1 ac	11.1 ac

No further specifications.

Fasteners for connection of steel structural members in steel and high bay warehouse structures

TDBL-T-8.6 x L
TDBLF-T-F-8.6 x L

Annex 38

<p style="text-align: center;">Ansicht = view</p> <p style="text-align: center;">Ansicht A</p> <p style="text-align: center;">Ansicht A</p>	<p>Materials</p> <p>Screw: Carbon steel tempered and coated</p> <p>Component I: S235 – EN 10025-2 S280GD through S320GD – EN 10346 HX300LAD – EN 10346</p> <p>Component II: S235 – EN 10025-2 S280GD through S320GD – EN 10346 HX300LAD – EN 10346</p> <hr/> <p><u>pre-drilling diameter</u></p> <p>Component I: slotted hole 6.5 mm x 10.0 mm Component II: see table</p>
---	---

		t_{II} [mm]															
		0.88	0.90	1.00	1.25	1.50	2.00	3.00	4.00	≥ 6.00							
		$d_{pd,II} = 7.5$ mm					$d_{pd,II} = 8.0$ mm										
$V_{R,k}$ [kN]	t_i [mm]	0.88	0.90	1.00	1.13	1.25	1.50	1.75	2.00	0.88	0.90	1.00	1.13	1.25	1.50	1.75	2.00
		1.49 ac	1.51 ac	1.62 ac	1.90 ac	2.18 ac	2.73 ac	2.73 ac	2.73 ac	2.73 ac	2.74 ac	2.74 ac	2.74 ac	2.74 ac	2.74 ac	2.74 ac	2.74 ac
		-	-	1.64 ac	1.90 ac	2.18 ac	2.73 ac	2.74 ac	2.74 ac	2.74 ac	2.74 ac	2.74 ac	2.74 ac	2.74 ac	2.74 ac	2.74 ac	2.74 ac
		-	-	1.64 ac	1.95 ac	2.30 ac	2.99 ac	4.38 ac	4.38 ac	4.38 ac	4.38 ac	4.38 ac	4.38 ac	4.38 ac	4.38 ac	4.38 ac	4.38 ac
		-	-	-	2.07 ac	2.35 ac	2.91 ac	4.38 ac	4.61 ac	4.61 ac	4.61 ac	4.61 ac	4.61 ac	4.61 ac	4.61 ac	4.61 ac	4.61 ac
		-	-	-	2.25 ac	2.49 ac	2.96 ac	4.38 ac	4.84 ac	4.84 ac	4.84 ac	4.84 ac	4.84 ac	4.84 ac	4.84 ac	4.84 ac	4.84 ac
		-	-	-	-	2.59 ac	3.33 ac	4.38 ac	4.84 ac	4.84 ac	4.84 ac	4.84 ac	4.84 ac	4.84 ac	4.84 ac	4.84 ac	4.84 ac
		-	-	-	-	-	3.33 ac	4.38 ac	4.84 ac	4.84 ac	4.84 ac	4.84 ac	4.84 ac	4.84 ac	4.84 ac	4.84 ac	4.84 ac
$N_{R,k}$ [kN]	t_i [mm]	0.88	0.90	1.00	1.13	1.25	1.50	1.75	2.00	0.88	0.90	1.00	1.13	1.25	1.50	1.75	2.00
		1.10 ac	1.13 ac	1.29 ac	1.84 ac	2.59 ac	3.43 ac	3.43 ac	3.43 ac	3.43 ac	3.45 ac	3.45 ac	3.45 ac	3.45 ac	3.45 ac	3.45 ac	3.45 ac
		-	1.13 ac	1.29 ac	1.84 ac	2.59 ac	3.45 ac	3.45 ac	3.45 ac	3.45 ac	3.45 ac	3.45 ac	3.45 ac	3.45 ac	3.45 ac	3.45 ac	3.45 ac
		-	-	1.29 ac	1.84 ac	2.59 ac	3.52 ac	3.52 ac	3.52 ac	3.52 ac	3.52 ac	3.52 ac	3.52 ac	3.52 ac	3.52 ac	3.52 ac	3.52 ac
		-	-	1.29 ac	1.84 ac	2.59 ac	3.88 ac	4.56 ac	4.56 ac	4.56 ac	4.56 ac	4.56 ac	4.56 ac	4.56 ac	4.56 ac	4.56 ac	4.56 ac
		-	-	-	1.84 ac	2.59 ac	3.88 ac	5.60 ac	5.60 ac	5.60 ac	5.60 ac	5.60 ac	5.60 ac	5.60 ac	5.60 ac	5.60 ac	5.60 ac
		-	-	-	-	2.59 ac	3.88 ac	7.63 ac	7.63 ac	7.63 ac	7.63 ac	7.63 ac	7.63 ac	7.63 ac	7.63 ac	7.63 ac	7.63 ac
		-	-	-	-	-	3.88 ac	7.63 ac	7.63 ac	7.63 ac	7.63 ac	7.63 ac	7.63 ac	7.63 ac	7.63 ac	7.63 ac	7.63 ac



Fasteners for connection of steel structural members in steel and high bay warehouse structures

TDBL-T-8.6 x L
TDBLF-T-F-8.6 x L

Annex 39

Ansicht = view

Materials

Screw: Carbon steel tempered and coated

Component I: S275 through S355 – EN 10025-2
 S350GD through S450GD – EN 10346
 HX340LAD through HX460LAD – EN 10346

Component II: S275 through S355 – EN 10025-2
 S350GD through S450GD – EN 10346
 HX340LAD through HX460LAD – EN 10346

pre-drilling diameter

Component I: slotted hole 6.5 mm x 10.0 mm
 Component II: see table

		t_{II} [mm]									
		0.88	0.90	1.00	1.25	1.50	2.00	3.00	4.00	≥ 6.00	
		$d_{pd,II} = 7.5$ mm					$d_{pd,II} = 8.0$ mm				
$V_{R,k}$ [kN]	0.88	1.70 ac	1.73 ac	1.85 ac	2.17 ac	2.48 ac	3.11 ac	3.11 ac	3.11 ac	3.11 ac	
	0.90	-	-	1.76 ac	1.89 ac	2.22 ac	2.55 ac	3.20 ac	3.42 ac	3.42 ac	
	1.00	-	-	-	1.89 ac	2.22 ac	2.61 ac	3.41 ac	4.99 ac	4.99 ac	
	1.13	-	-	-	-	2.37 ac	2.69 ac	3.41 ac	4.99 ac	5.26 ac	
	t_I [mm]	1.25	-	-	-	-	2.59 ac	2.86 ac	3.41 ac	4.99 ac	5.52 ac
	1.50	-	-	-	-	-	-	2.94 ac	3.41 ac	4.99 ac	5.52 ac
	1.75	-	-	-	-	-	-	-	3.41 ac	4.99 ac	5.52 ac
	2.00	-	-	-	-	-	-	-	3.41 ac	4.99 ac	5.52 ac
$N_{R,k}$ [kN]	0.88	1.11 ac	1.16 ac	1.42 ac	1.88 ac	2.66 ac	4.00 ac	4.00 ac	4.00 ac	4.00 ac	
	0.90	-	-	1.16 ac	1.42 ac	1.88 ac	2.66 ac	4.02 ac	4.02 ac	4.02 ac	
	1.00	-	-	-	1.42 ac	1.88 ac	2.66 ac	4.11 ac	4.11 ac	4.11 ac	
	1.13	-	-	-	-	1.88 ac	2.66 ac	4.42 ac	5.32 ac	5.32 ac	
	t_I [mm]	1.25	-	-	-	-	1.88 ac	2.66 ac	4.42 ac	6.53 ac	
	1.50	-	-	-	-	-	-	2.66 ac	4.42 ac	8.90 ac	
	1.75	-	-	-	-	-	-	-	4.42 ac	8.90 ac	
	2.00	-	-	-	-	-	-	-	4.42 ac	8.90 ac	

Further specifications:

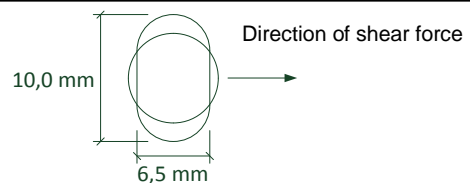

Fasteners for connection of steel structural members in steel and high bay warehouse structures

TDBL-T-8.6 x L
 TDBLF-T-F-8.6 x L

Annex 40

<p style="text-align: center;">Ansicht = view</p> <p style="text-align: center;">Ansicht A</p> <p style="text-align: center;">Ansicht A</p>	<p>Materials</p> <p>Screw: Carbon steel tempered and coated</p> <p>Component I: S275 through S355 – EN 10025-2 S350GD through S450GD – EN 10346 HX340LAD through HX460LAD – EN 10346</p> <p>Component II: S275 through S355 – EN 10025-2 S350GD through S450GD – EN 10346 HX340LAD through HX460LAD – EN 10346</p> <p><u>pre-drilling diameter</u></p> <p>Component I: slotted hole 6.5 mm x 10.0 mm Component II: see table</p>
---	---

		t_{II} [mm]									
		0.88	0.90	1.00	1.25	1.50	2.00	3.00	4.00	≥ 6.00	
									$d_{pd,II} = 8.0$ mm		
$V_{R,k}$ [kN]	t_I [mm]	2 x 0.88	- -	- -	- -	- -	- -	- -	4.91 ac	4.91 ac	4.91 ac
		2 x 0.90	- -	- -	- -	- -	- -	- -	5.64 ac	5.64 ac	5.64 ac
		2 x 1.00	- -	- -	- -	- -	- -	- -	6.37 ac	6.37 ac	6.37 ac
		2 x 1.13	- -	- -	- -	- -	- -	- -	5.54 ac	7.66 ac	7.66 ac
		2 x 1.25	- -	- -	- -	- -	- -	- -	6.76 ac	8.95 ac	8.95 ac
		2 x 1.50	- -	- -	- -	- -	- -	- -	5.69 ac	7.42 ac	10.9 ac
		2 x 1.75	- -	- -	- -	- -	- -	- -	5.69 ac	7.42 ac	10.9 ac
		2 x 2.00	- -	- -	- -	- -	- -	- -	5.69 ac	7.42 ac	22.7 ac
$N_{R,k}$ [kN]	t_I [mm]	2 x 0.88	- -	- -	- -	- -	- -	- -	3.43 ac	3.43 ac	3.43 ac
		2 x 0.90	- -	- -	- -	- -	- -	- -	3.45 ac	3.45 ac	3.45 ac
		2 x 1.00	- -	- -	- -	- -	- -	- -	3.52 ac	3.52 ac	3.52 ac
		2 x 1.13	- -	- -	- -	- -	- -	- -	4.56 ac	4.56 ac	4.56 ac
		2 x 1.25	- -	- -	- -	- -	- -	- -	5.60 ac	5.60 ac	5.60 ac
		2 x 1.50	- -	- -	- -	- -	- -	- -	7.63 ac	7.63 ac	7.63 ac
		2 x 1.75	- -	- -	- -	- -	- -	- -	7.63 ac	7.63 ac	7.63 ac
		2 x 2.00	- -	- -	- -	- -	- -	- -	7.63 ac	7.63 ac	7.63 ac

Further specifications:

Fasteners for connection of steel structural members in steel and high bay warehouse structures	Annex 41
TDBL-T-8.6 x L TDBLF-T-F-8.6 x L	

<p style="text-align: center;">Ansicht = view</p> <p style="text-align: center;">Ansicht A</p> <p style="text-align: center;">Ansicht A</p>	<p><u>Materials</u></p> <p>Screw: Carbon steel tempered and coated</p> <p>Component I: S235 – EN 10025-2 S280GD through S320GD – EN 10346 HX300LAD – EN 10346</p> <p>Component II: S235 – EN 10025-2 S280GD through S320GD – EN 10346 HX300LAD – EN 10346</p> <hr/> <p><u>pre-drilling diameter</u></p> <p>Component I: slotted hole 6.5 mm x 10.0 mm Component II: slotted hole 6.5 mm x 10.0 mm</p>
---	---

		t_{II} [mm]							
		0.88	0.90	1.00	1.25	1.50	2.00	3.00	4.00
		$d_{pd.I} = d_{pd.II} = \text{slotted hole } 6.5 \text{ mm} \times 10.0 \text{ mm}$							
$V_{R.k}$ [kN]	t_i [mm]	0.88	0.90	1.00	1.25	1.50	2.00	3.00	4.00
	0.88	1.49 -	1.49 -	1.49 -	1.49 -	1.49 -	1.49 -	1.49 -	1.49 -
	0.90	- -	1.55 -	1.55 -	1.55 -	1.55 -	1.55 -	1.55 -	1.55 -
	1.00	- -	- -	1.60 -	1.60 -	1.60 -	1.60 -	1.60 -	1.60 -
	1.13	- -	- -	- -	1.93 -	1.93 -	1.93 -	1.93 -	1.93 -
	1.25	- -	- -	- -	2.25 -	2.25 -	2.25 -	2.25 -	2.25 -
	1.50	- -	- -	- -	- -	2.59 -	2.59 -	2.59 -	2.59 -
	1.75	- -	- -	- -	- -	- -	2.59 -	2.59 -	2.59 -
2.00	- -	- -	- -	- -	- -	2.59 -	2.59 -	2.59 -	
$N_{R.k}$ [kN]	t_i [mm]	0.88	0.90	1.00	1.25	1.50	2.00	3.00	4.00
	0.88	0.87 -	0.88 -	0.94 -	1.37 -	1.73 -	1.73 -	1.73 -	1.73 -
	0.90	- -	0.88 -	0.94 -	1.37 -	1.73 -	1.73 -	1.73 -	1.73 -
	1.00	- -	- -	0.94 -	1.37 -	1.73 -	1.73 -	1.73 -	1.73 -
	1.13	- -	- -	- -	1.37 -	1.73 -	1.73 -	1.73 -	1.73 -
	1.25	- -	- -	- -	1.37 -	1.73 -	1.73 -	1.73 -	1.73 -
	1.50	- -	- -	- -	- -	1.73 -	1.73 -	1.73 -	1.73 -
	1.75	- -	- -	- -	- -	- -	1.73 -	1.73 -	1.73 -
2.00	- -	- -	- -	- -	- -	1.73 -	1.73 -	1.73 -	

Further specifications:

Fasteners for connection of steel structural members in steel and high bay warehouse structures	Annex 42
TDBL-T-8.6 x L TDBLF-T-F-8.6 x L	

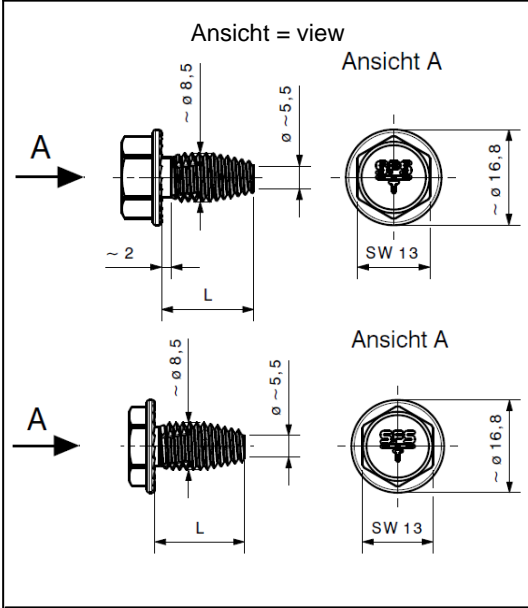

Materials

Screw: Carbon steel
 tempered and coated

Component I: S275 through S355 – EN 10025-2
 S350GD through S450GD – EN 10346
 HX340LAD through HX460LAD – EN 10346

Component II: S275 through S355 – EN 10025-2
 S350GD through S450GD – EN 10346
 HX340LAD through HX460LAD – EN 10346

pre-drilling diameter

Component I: slotted hole 6.5 mm x 10.0 mm
 Component II: slotted hole 6.5 mm x 10.0 mm

		t_{II} [mm]								
		0.88	0.90	1.00	1.25	1.50	2.00	3.00	4.00	
		$d_{pd.I} = d_{pd.II} =$ slotted hole 6.5 mm x 10.0 mm								
$V_{R,k}$ [kN]	0.88	1.70 -	1.70 -	1.70 -	1.70 -	1.70 -	1.70 -	1.70 -	1.70 -	
	0.90	- -	1.69 -	1.76 -	1.76 -	1.76 -	1.76 -	1.76 -	1.76 -	
	1.00	- -	- -	1.82 -	1.82 -	1.82 -	1.82 -	1.82 -	1.82 -	
	1.13	- -	- -	- -	2.21 -	2.21 -	2.21 -	2.21 -	2.21 -	
	t_I [mm]	1.25	- -	- -	- -	2.59 -	2.59 -	2.59 -	2.59 -	2.59 -
		1.50	- -	- -	- -	- -	2.94 -	2.94 -	2.94 -	2.94 -
		1.75	- -	- -	- -	- -	- -	2.94 -	2.94 -	2.94 -
2.00		- -	- -	- -	- -	- -	2.94 -	2.94 -	2.94 -	
$N_{R,k}$ [kN]	0.88	0.99 -	1.00 -	1.07 -	1.56 -	1.97 -	1.97 -	1.97 -	1.97 -	
	0.90	- -	1.00 -	1.07 -	1.56 -	1.97 -	1.97 -	1.97 -	1.97 -	
	1.00	- -	- -	1.07 -	1.56 -	1.97 -	1.97 -	1.97 -	1.97 -	
	1.13	- -	- -	- -	1.56 -	1.97 -	1.97 -	1.97 -	1.97 -	
	t_I [mm]	1.25	- -	- -	- -	1.56 -	1.97 -	1.97 -	1.97 -	1.97 -
		1.50	- -	- -	- -	- -	1.97 -	1.97 -	1.97 -	1.97 -
		1.75	- -	- -	- -	- -	- -	1.97 -	1.97 -	1.97 -
		2.00	- -	- -	- -	- -	- -	1.97 -	1.97 -	1.97 -

Further specifications:

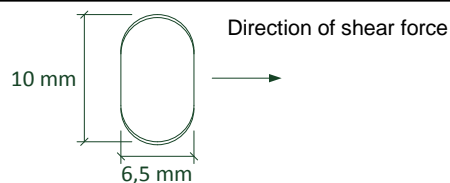

Fasteners for connection of steel structural members in steel and high bay warehouse structures

TDBL-T-8.6 x L
 TDBLF-T-F-8.6 x L

Annex 43

<p style="text-align: center;">Ansicht = view</p> <p style="text-align: center;">Ansicht A</p> <p style="text-align: center;">Ansicht A</p>	<p>Materials</p> <p>Screw: Carbon steel tempered and coated</p> <p>Component I: S275 through S355 – EN 10025-2 S350GD through S450GD – EN 10346 HX340LAD through HX460LAD – EN 10346</p> <p>Component II: S275 through S355 – EN 10025-2 S350GD through S450GD – EN 10346 HX340LAD through HX460LAD – EN 10346</p> <hr/> <p>pre-drilling diameter</p> <p>Component I: slotted hole 6.5 mm x 10.0 mm Component II: slotted hole 6.5 mm x 10.0 mm</p>
---	---

		t_{II} [mm]										
		0.88	0.90	1.00	1.25	1.50	2.00	3.00	4.00			
		$d_{pd.I} = d_{pd.II} = \text{slotted hole } 6.5 \text{ mm} \times 10.0 \text{ mm}$										
$V_{R,k}$ [kN]	2 x 0.88	-	-	-	-	-	-	1.89	-	1.89	-	
	2 x 0.90	-	-	-	-	-	-	1.89	-	1.89	-	
	2 x 1.00	-	-	-	-	-	-	1.89	-	1.89	-	
	2 x 1.13	-	-	-	-	-	-	2.41	-	2.41	-	
	t_I [mm]	2 x 1.25	-	-	-	-	-	-	2.93	-	2.93	-
		2 x 1.50	-	-	-	-	-	-	3.08	-	3.08	-
		2 x 1.75	-	-	-	-	-	-	3.08	-	3.08	-
		2 x 2.00	-	-	-	-	-	-	3.08	-	3.08	-
$N_{R,k}$ [kN]	2 x 0.88	-	-	-	-	-	-	1.73	-	1.73	-	
	2 x 0.90	-	-	-	-	-	-	1.73	-	1.73	-	
	2 x 1.00	-	-	-	-	-	-	1.73	-	1.73	-	
	2 x 1.13	-	-	-	-	-	-	1.73	-	1.73	-	
	t_I [mm]	2 x 1.25	-	-	-	-	-	-	1.73	-	1.73	-
		2 x 1.50	-	-	-	-	-	-	1.73	-	1.73	-
		2 x 1.75	-	-	-	-	-	-	1.73	-	1.73	-
		2 x 2.00	-	-	-	-	-	-	1.73	-	1.73	-

Further specifications:

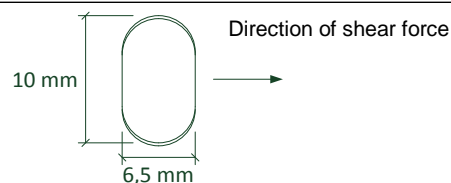

Fasteners for connection of steel structural members in steel and high bay warehouse structures

TDBL-T-8.6 x L
TDBLF-T-F-8.6 x L

Annex 44

This is a certified true translation of the original document presented to me in German.
The original document comprises 51 pages.
Sworn translator, duly commissioned by the Regional Court of Tübingen.
05 March 2019.

Pascal

Duchesnes

