

(P)	(C)	(N)
2	5.13.38.18	
3	7.13.07.36	
4	7.11.35.33	
6	5.04.29.12	
8	5.15.26.31	
9	5.13.10.05	
10	5.04.29.13	
11	5.13.10.06	
14		
15	5.10.01.57	
16	5.13.38.19	
17	5.18.25.96	
18	5.06.30.72	
19	5.10.03.55	
20	5.14.21.11	
21	0.17.18.31	
23	5.10.03.56	
24	5.21.40.41	
25	5.12.40.94	
26	5.13.10.07	
27		
28	5.12.40.95	
29	0.55.12.04	
30	5.10.01.59	
31	5.10.03.57	
32	5.18.19.25	
33		
34	0.80.12.13	
37		
38	5.08.01.85	
39	5.06.40.31	
42	5.17.30.38	
43	5.08.01.84	
44	0.14.01.24	
46	0.14.01.20	
47	5.21.42.40	
48	5.10.01.60	
49	0.55.12.03	
50	3.28.00.56	
52	0.10.01.16	
53	5.10.03.58	
54	5.13.09.87	
55	0.14.01.21	
56	5.14.21.10	
57	5.10.03.59	
58	5.18.19.05	
59	5.08.01.86	
60	5.14.21.09	
61	0.55.14.06	
62	5.18.25.94	
63	0.14.01.23	
64	5.08.01.87	
67	5.13.38.20	
68	5.00.20.59	
69	5.00.20.60	
70	0.80.12.14	
71	5.13.10.08	
73	0.24.03.11	
74	5.13.10.09	
75	5.10.03.60	
76	5.18.19.26	
77	5.14.21.12	
79	0.60.06.08	
80	5.40.28.02	
81	1.72.58.09	
82	0.24.14.66	
83	5.15.26.32	
84	5.18.19.27	
85	0.13.50.03	
87	5.40.28.03	
88	5.10.03.61	
90	5.00.20.61	
91	5.13.10.10	
92	5.13.10.35	
93	5.06.30.71	
94	0.80.23.28	
96	0.24.14.66	
99	5.18.19.28	

(P)	(C)	(N)
100	5.18.19.29	
101	5.13.38.02	
102	5.15.51.62	
103	5.15.51.63	
105	0.24.10.02	
106	5.10.03.62	
107	5.10.03.63	
109	0.15.51.59	
110	7.24.10.08	
111	5.24.11.12	
112	5.15.26.33	
113	5.04.29.14	
114	5.13.38.21	
115	7.80.02.80	
116	0.80.60.34	
117	5.14.21.13	
118	5.10.03.64	
119	5.06.30.73	
120	5.14.00.70	
121	0.80.60.35	
123	5.13.40.18	
124	5.10.03.65	
125	5.13.40.19	
127	5.15.26.34	
128	5.15.51.64	
129	5.13.38.22	
163	5.10.03.66	
G18	7.21.10.08	
M1	7.80.18.62	
M2	5.11.20.36	
M3	5.18.29.41	
T01	5.13.38.23	
T02	5.18.19.30	

N 310 DA DG

NR. 1

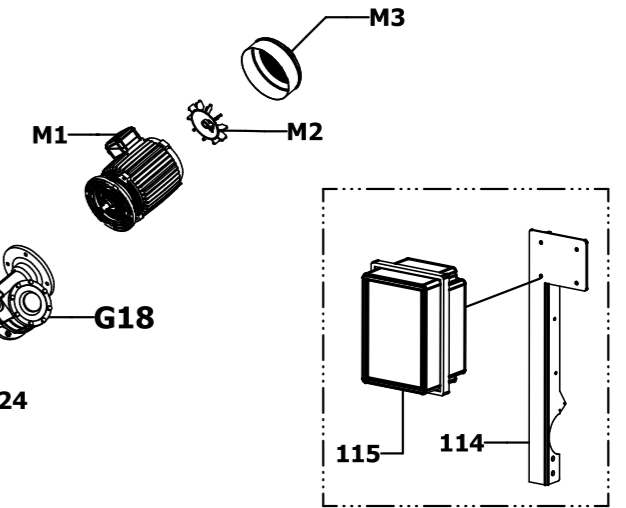
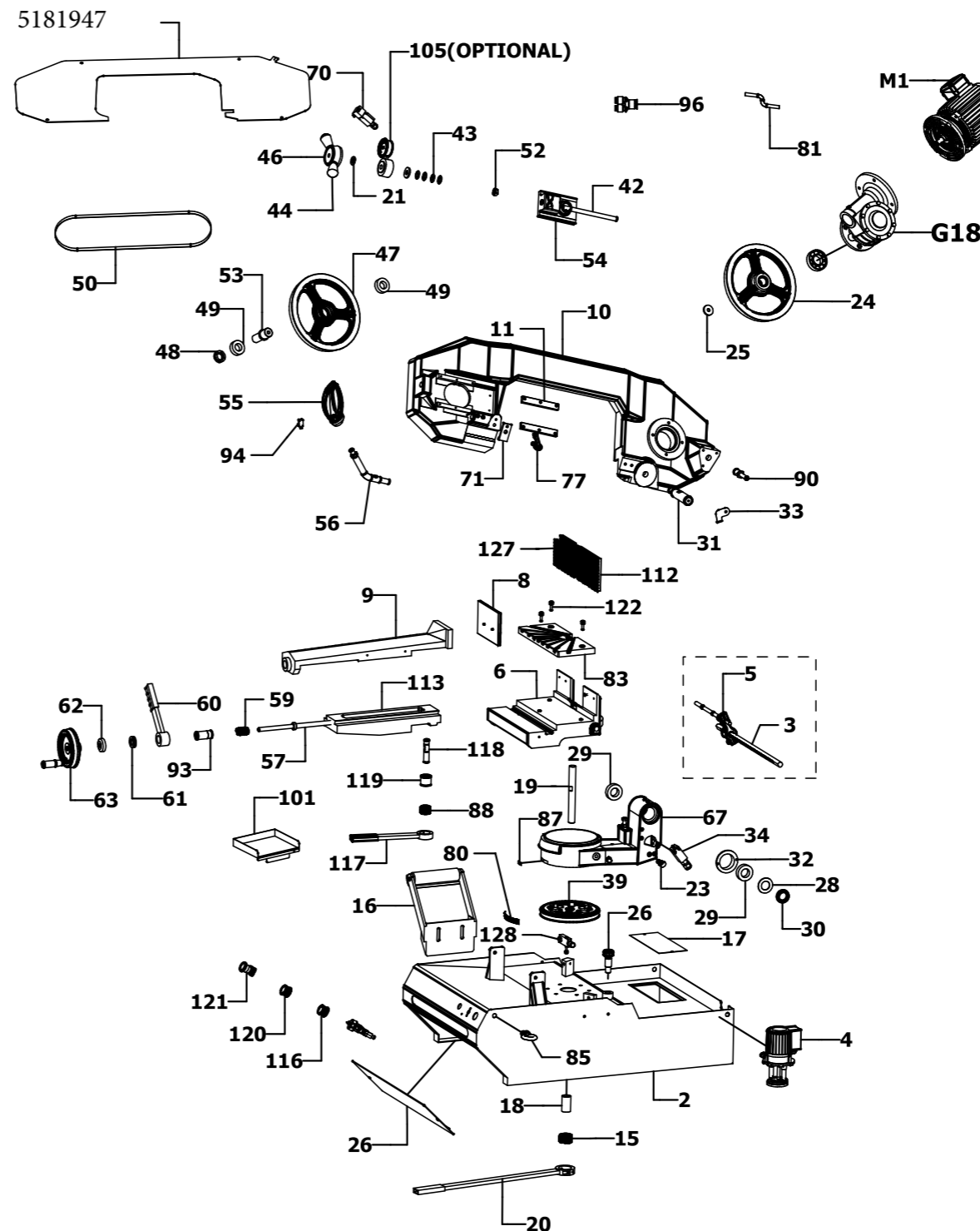
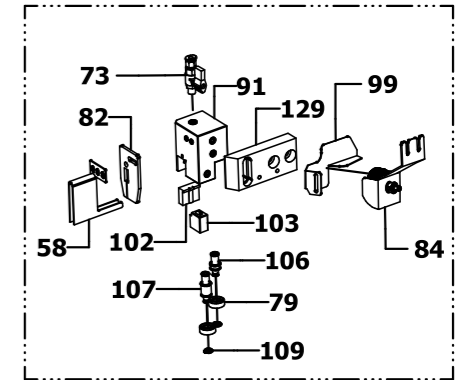
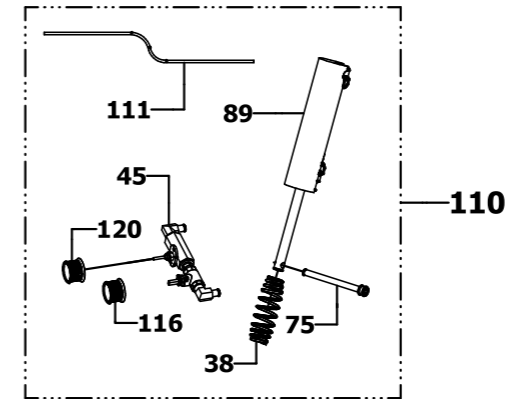
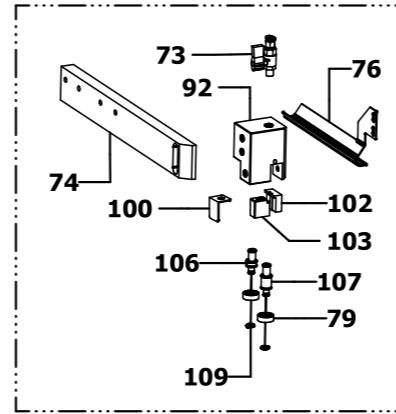

0820020 1/2 switch speed
 0820021 key switch aut/man
 0820022 cooling pump switch

